

IA64KR

KammRack

Instructions

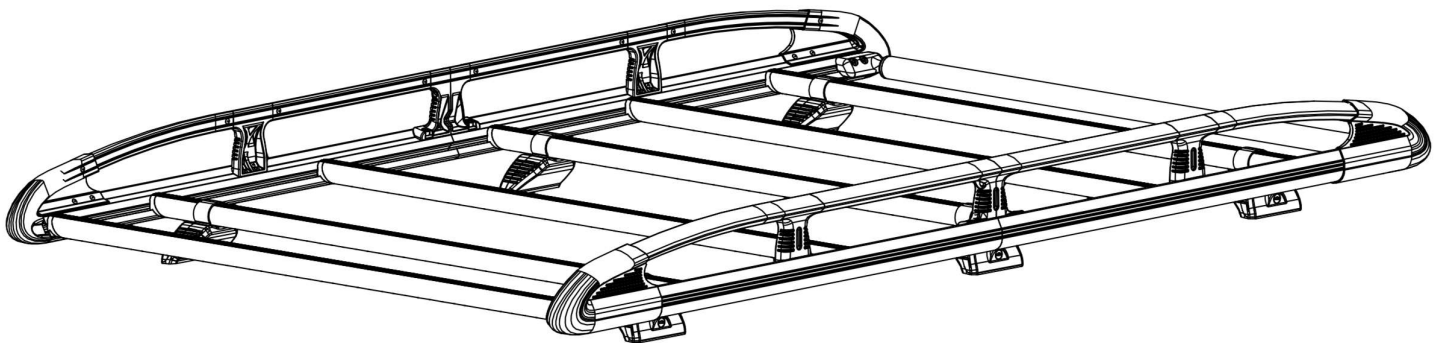

CITY CRASH (✓)

According to ISO/ PAS 11154:2006

IA64KR:

CITROEN Relay, 2006 – Onwards
PEUGEOT Boxer, 2006 – Onwards
FIAT Ducato, 2006 – Onwards
VAUXHALL Movano 2020- Onwards

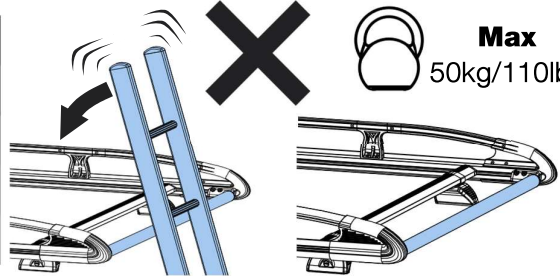
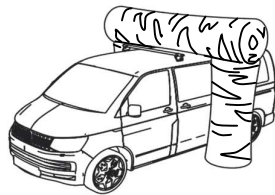
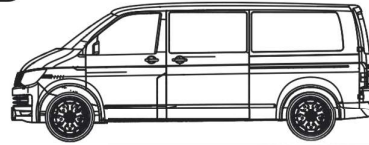

Max
50kg/110lbs

KammRack

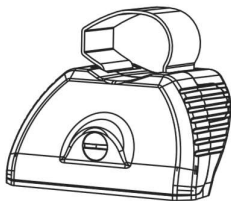

SA397U x 4

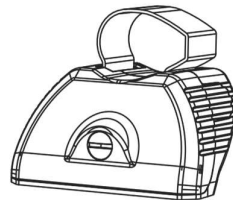

SA398U x 4

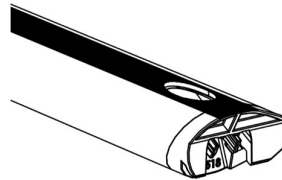

SA430



C04 x 8
optional upgrade

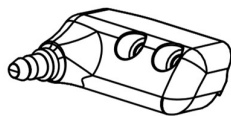

PS519 x 1

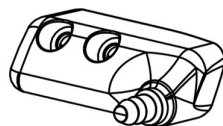

PS520 x 1

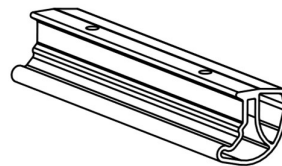

EXT15-02 x 4

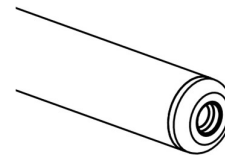

SA438 x 1

LHS x 2

RHS x 2

Centre x 2

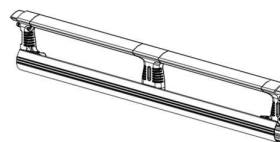
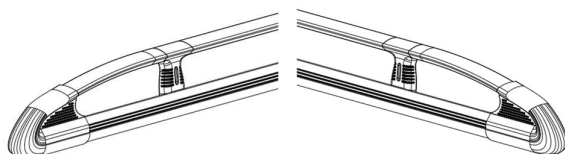

ASF x 1

Fitting Kit

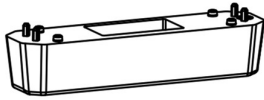

PS180 x 8

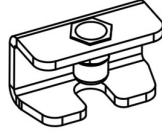

SA068 x 8

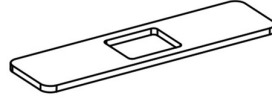

PS047 x 8



FT01 x 1

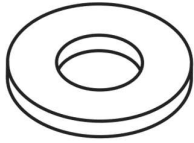

FW002 (M8) x 8

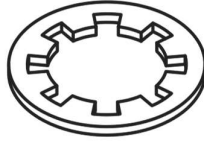

FW009 (M8) x 8

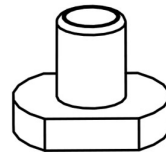

FN085 x 22



FS067
(M8 x 20) x 8



FS018
(M8 x 25) x 22



FT01 x 1

1.

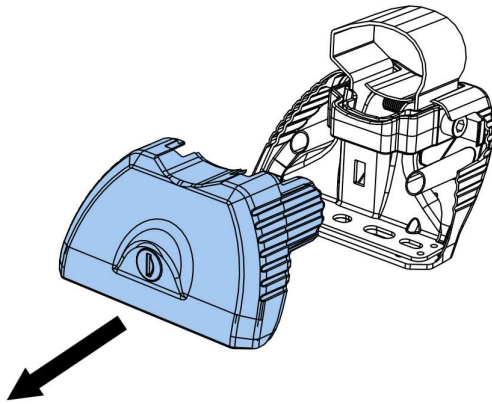

2.

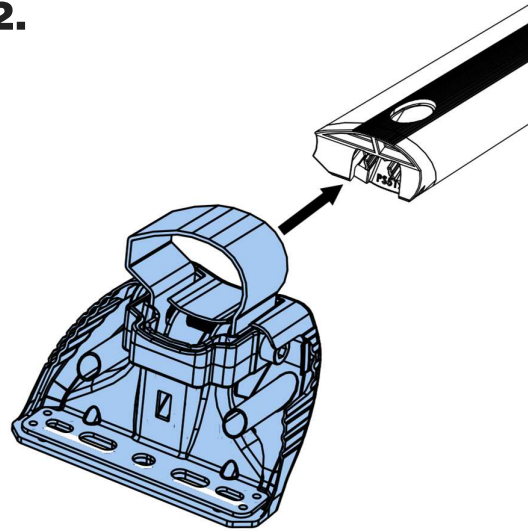

3.



SA397U
PS180



SA397U
PS180



SA397U
PS180



SA397U
PS180

R

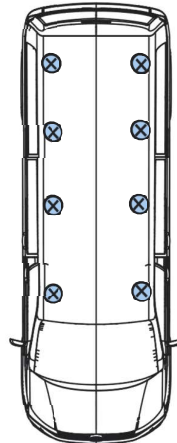

F

SA398U
PS180



SA398U
PS180



SA398U
PS180



SA398U
PS180



4.

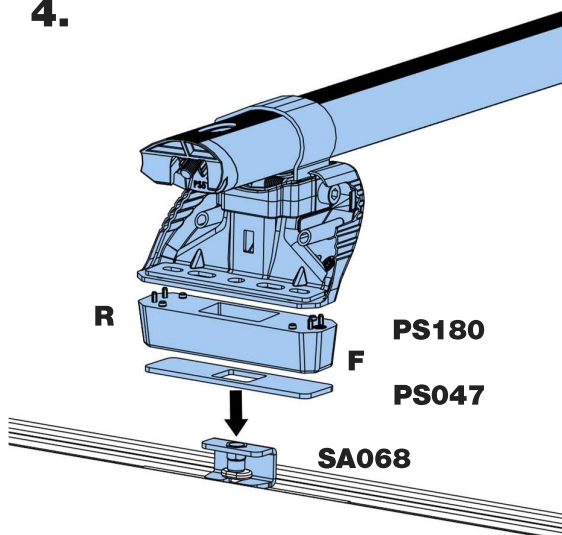

5.

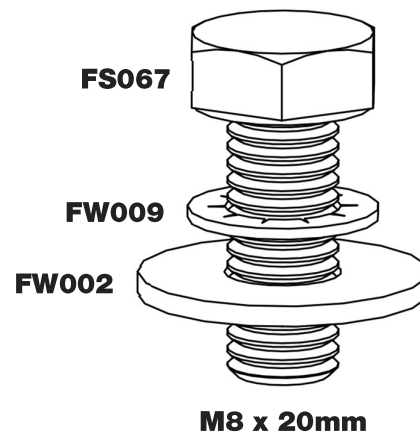

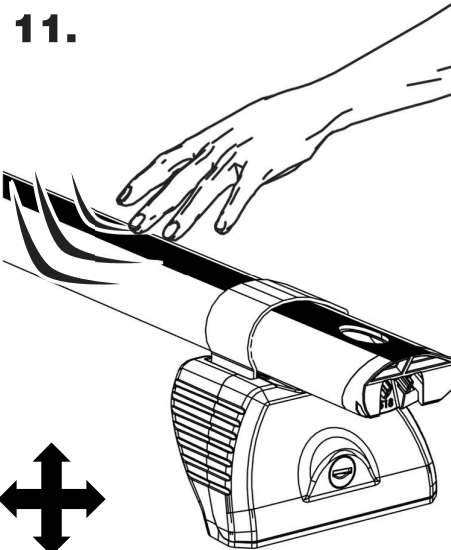
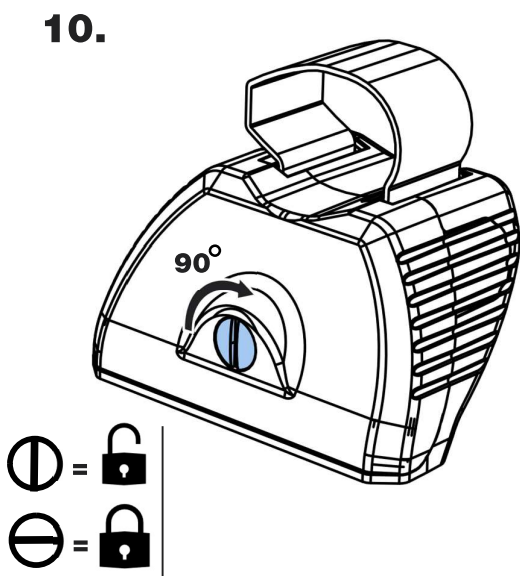
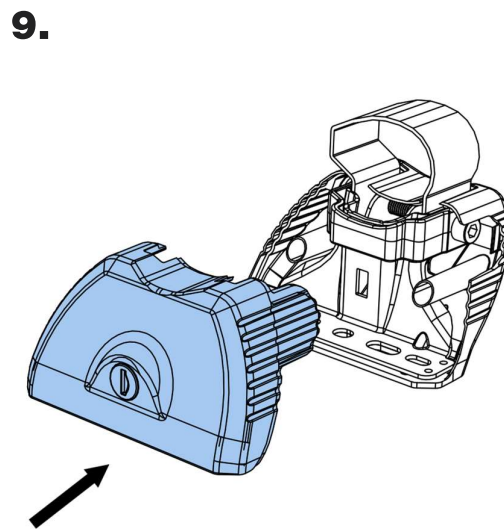
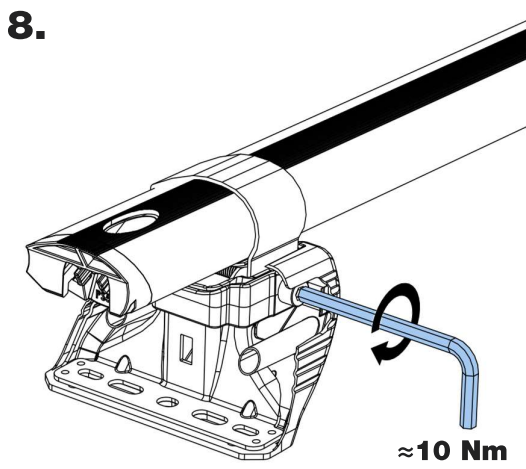
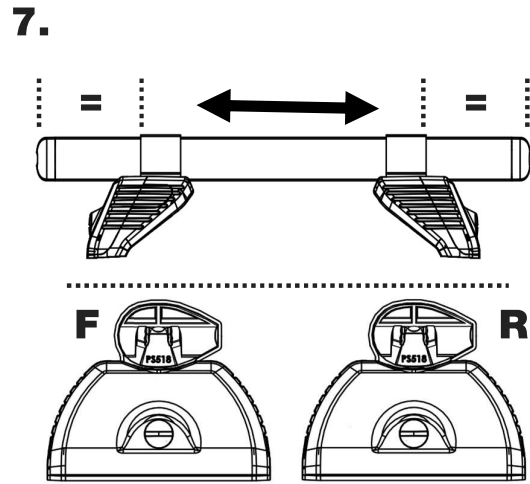
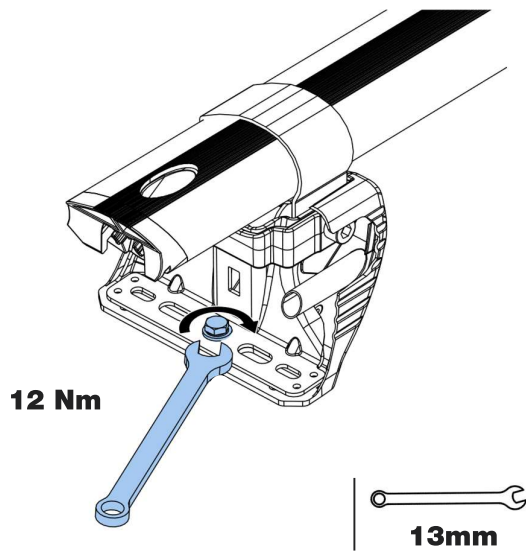

**K618- Jumper/Relay/Boxer/Ducato 2006-/Movano
2020- L4, H3, Twin Doors**

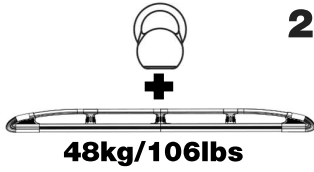

**150kg
Max**

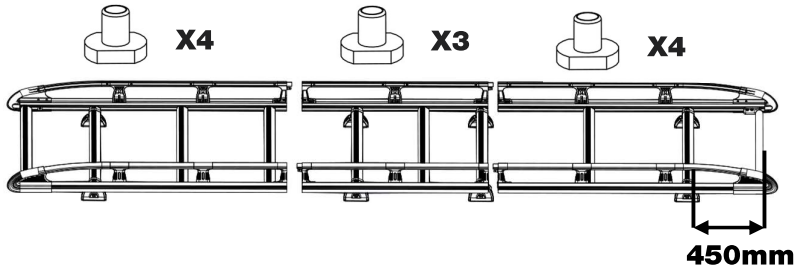
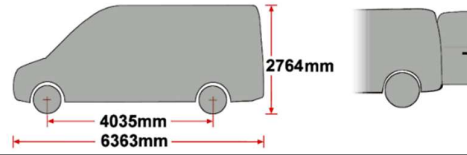

12.

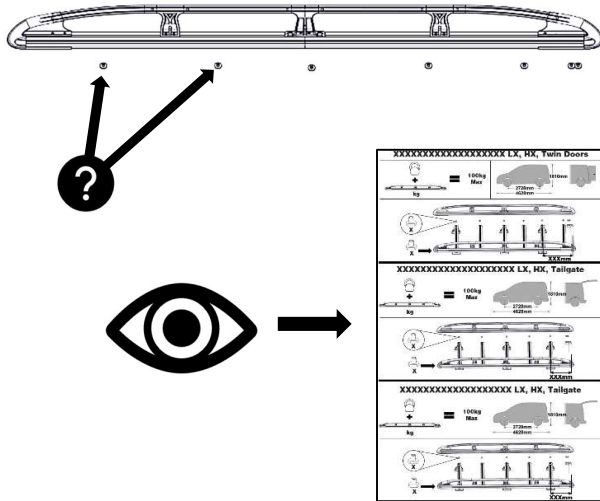

13.

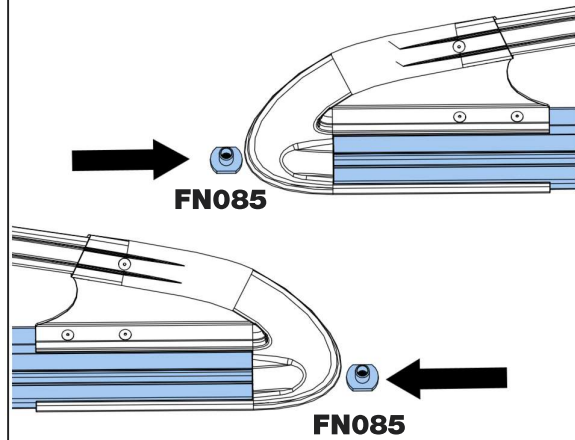

14.

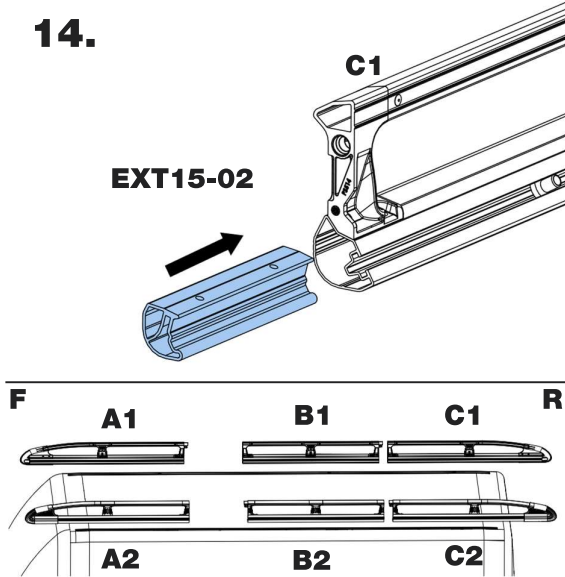

15.

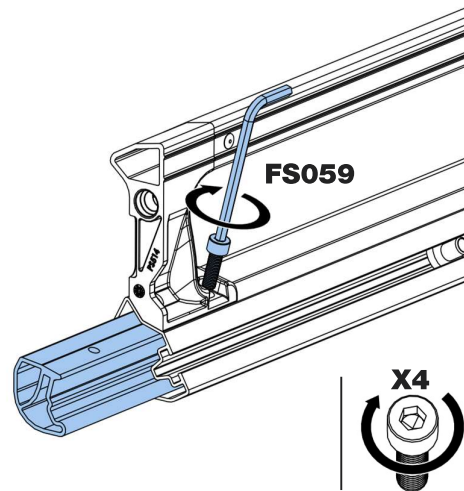

17.

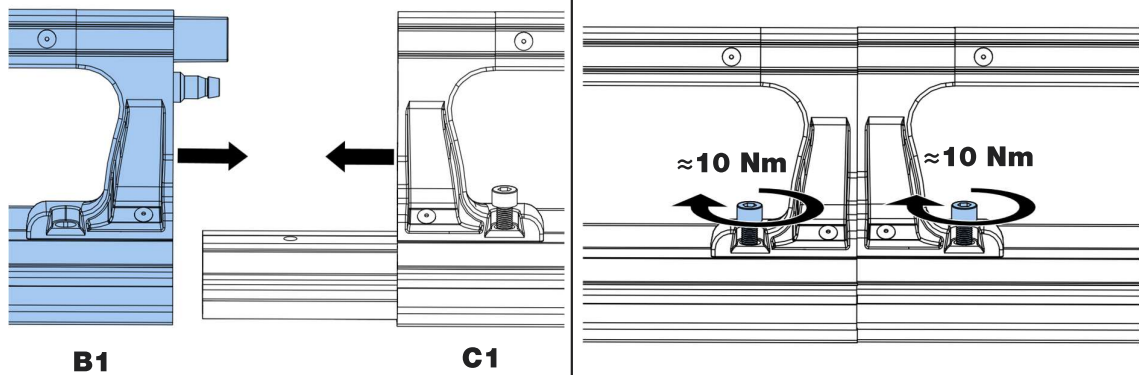

18.

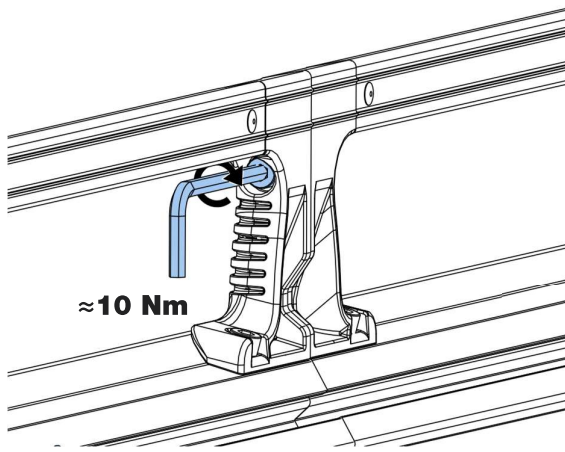

19.

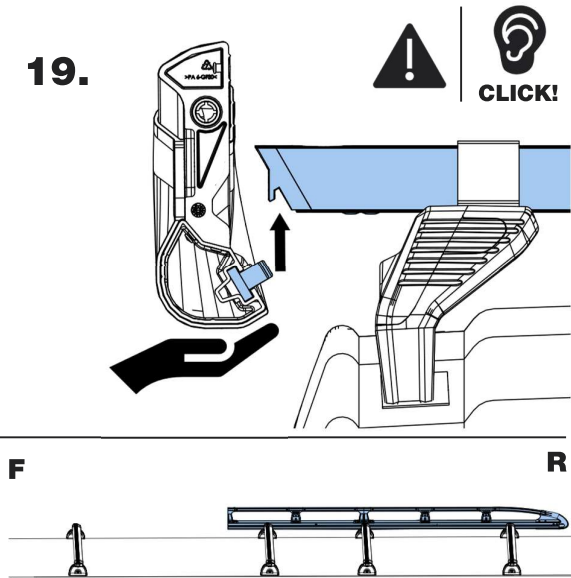

20.

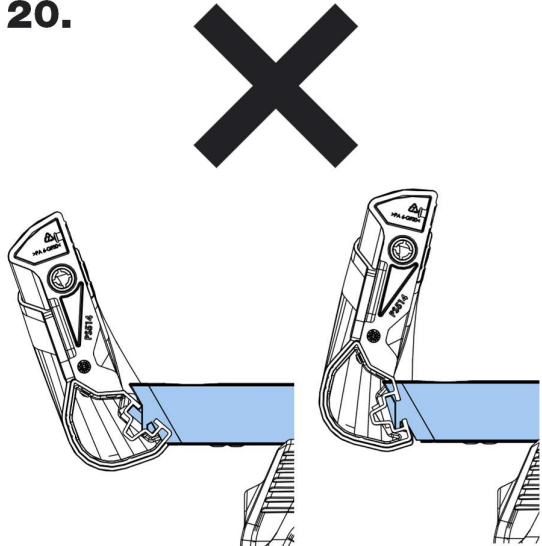

21.

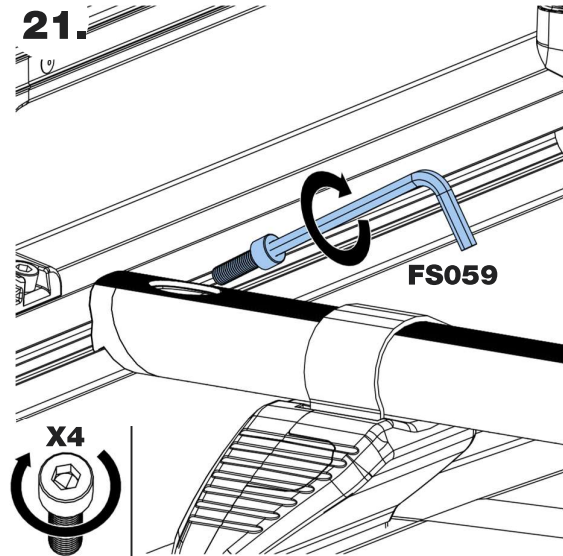

22.

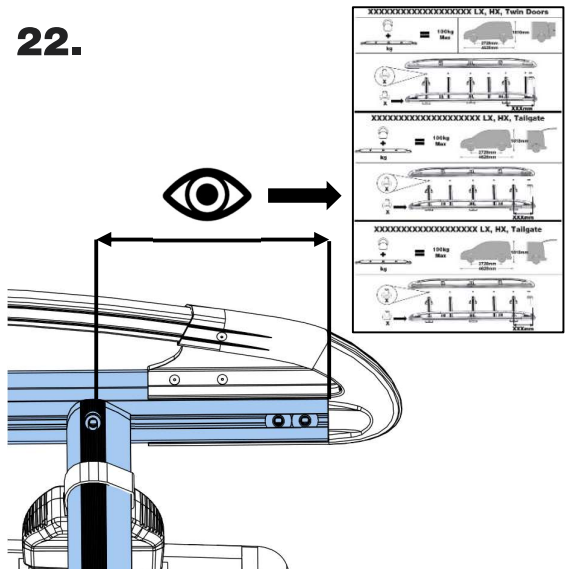

23.

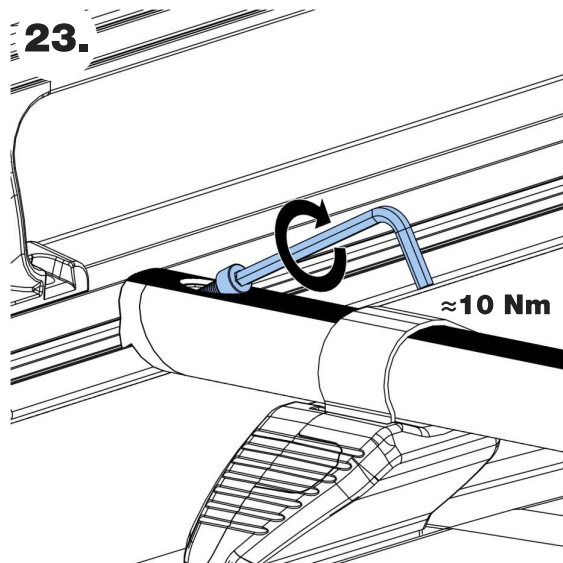

24.

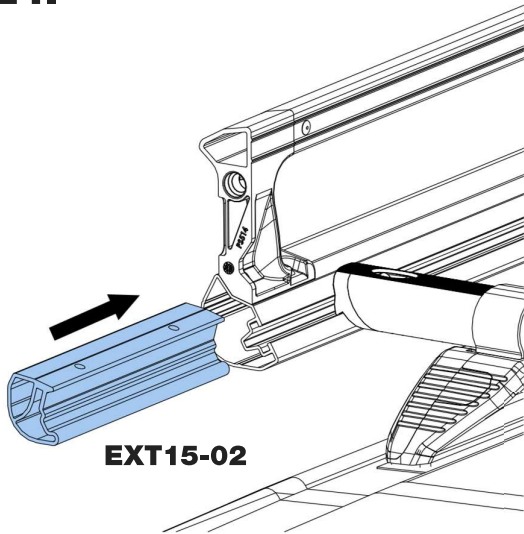

25.

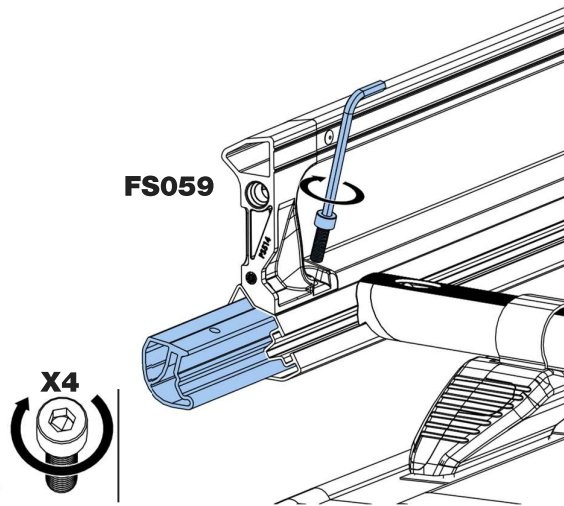

26.

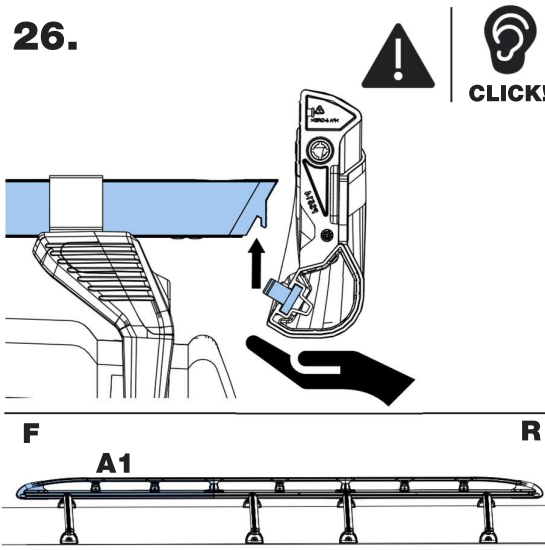

27.

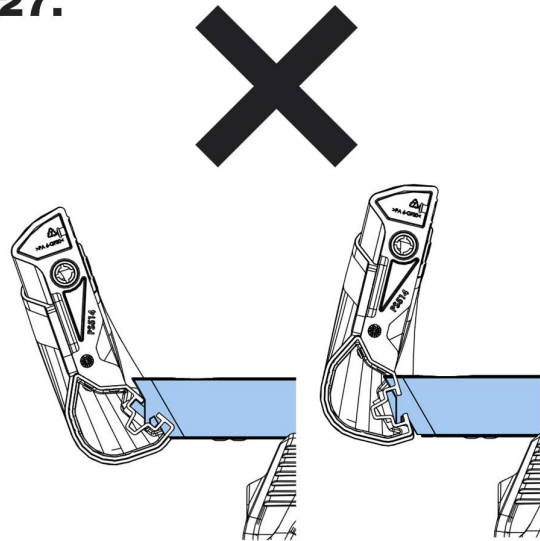

28.

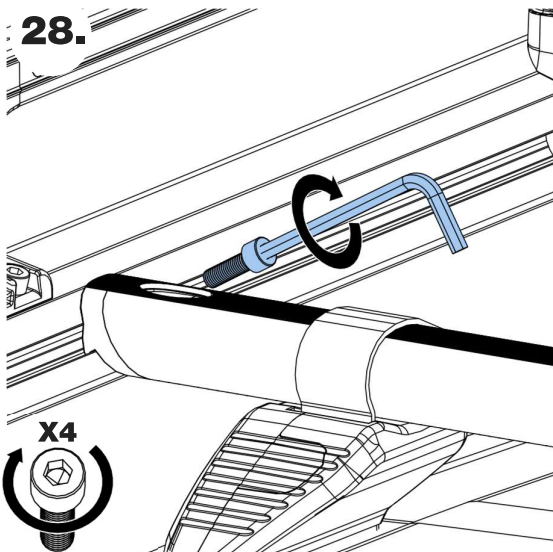

29.

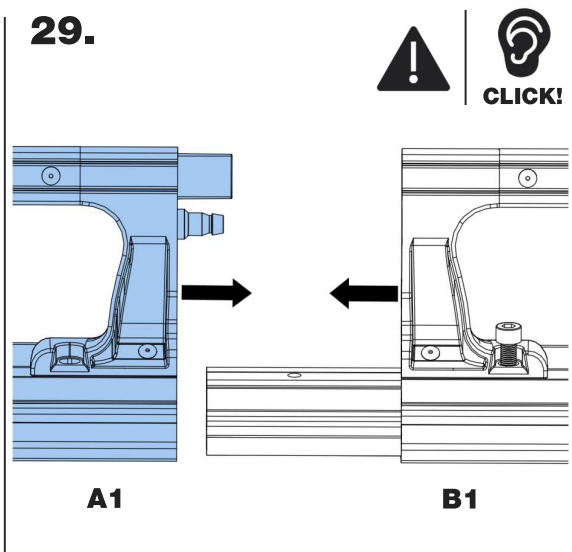

30.

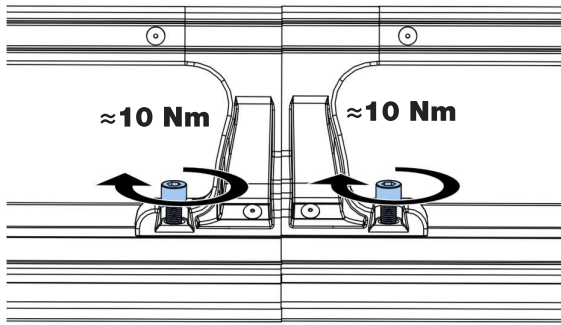

31.

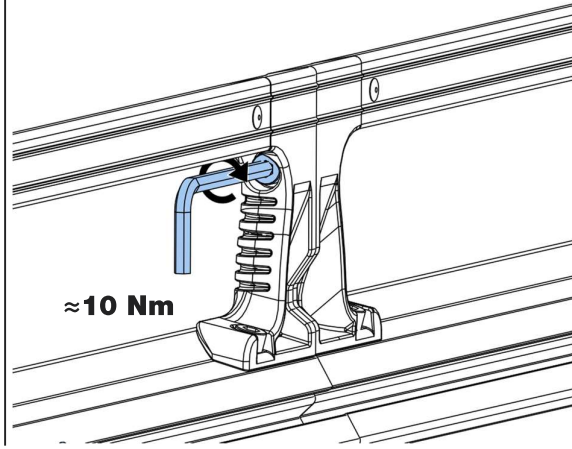

32.

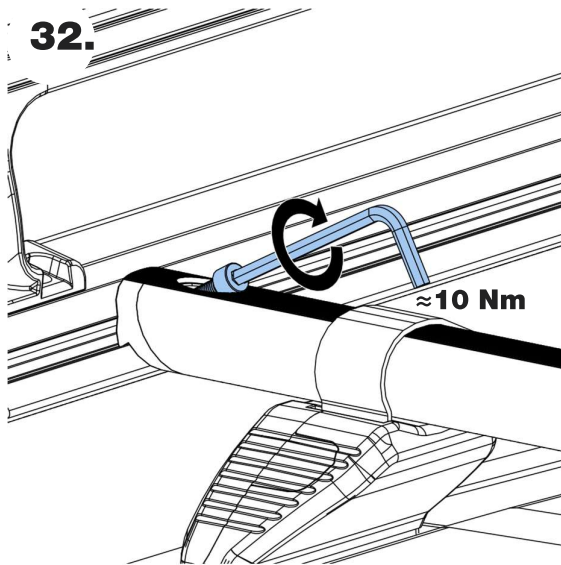

33.

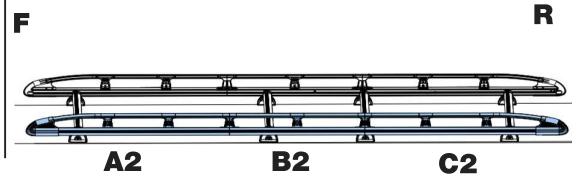
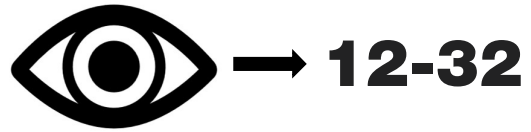

34.

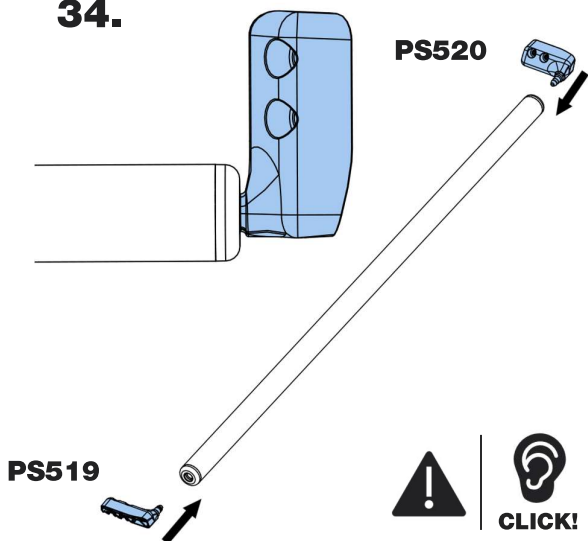

35.

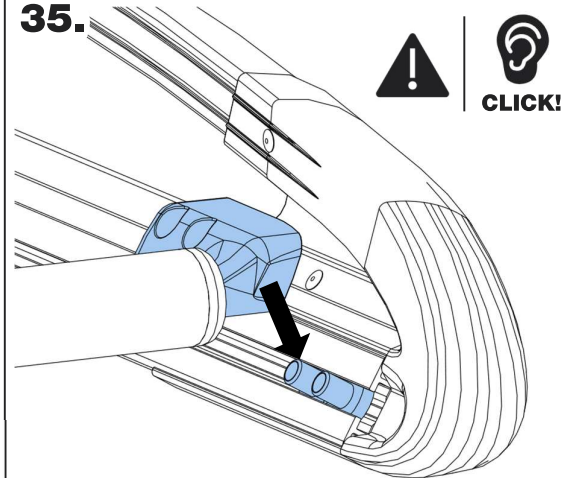

36.

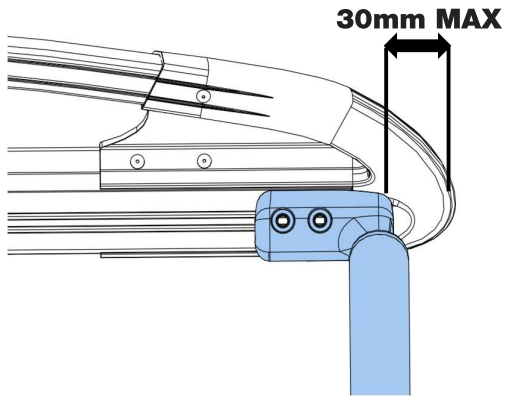

37.

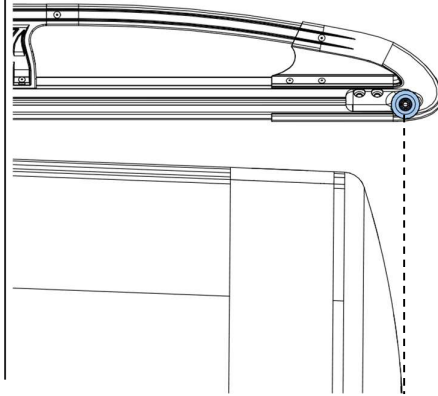

38.

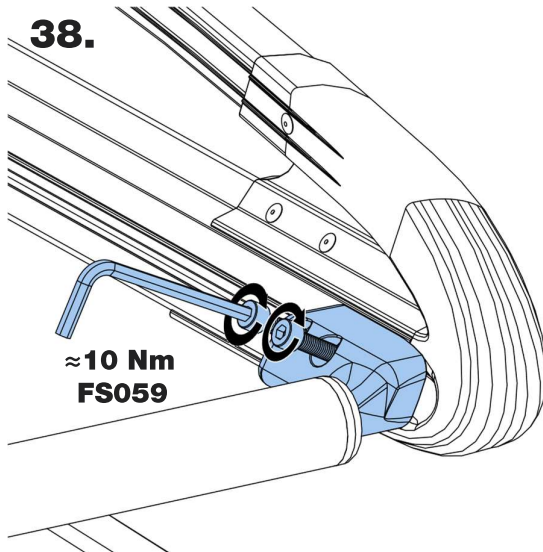

39.

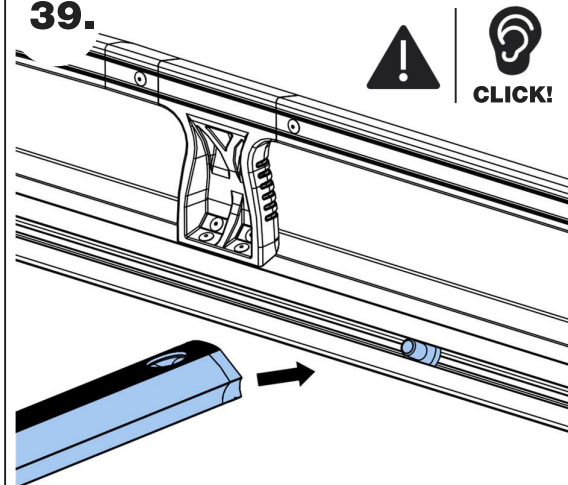

40.

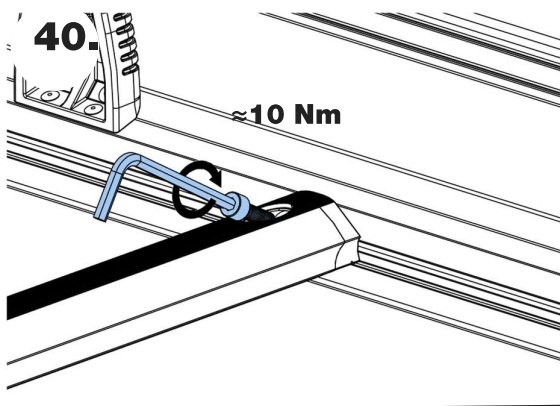

41.

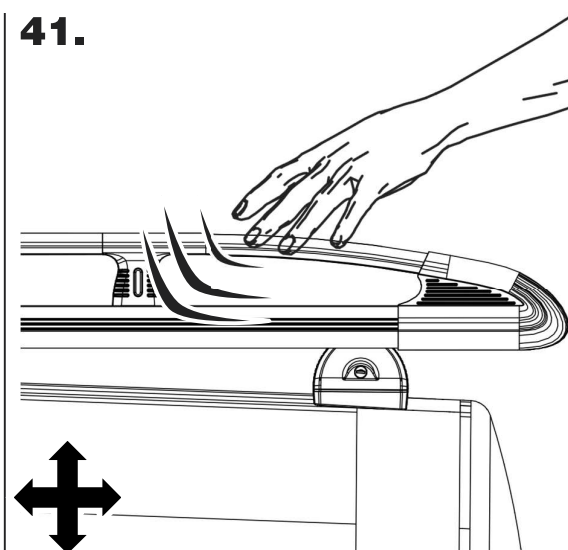

42.

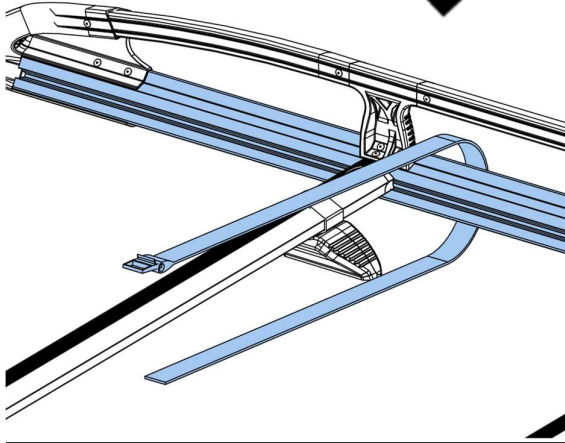

43.

