

Issue:	Drawn By:	Checked By:	CRF No.:	Date:	Description:
a	SJ	KB	3609	21/10/25	First Issue
b					
c					
d					

MC4KE

KammEdge.

Instructions

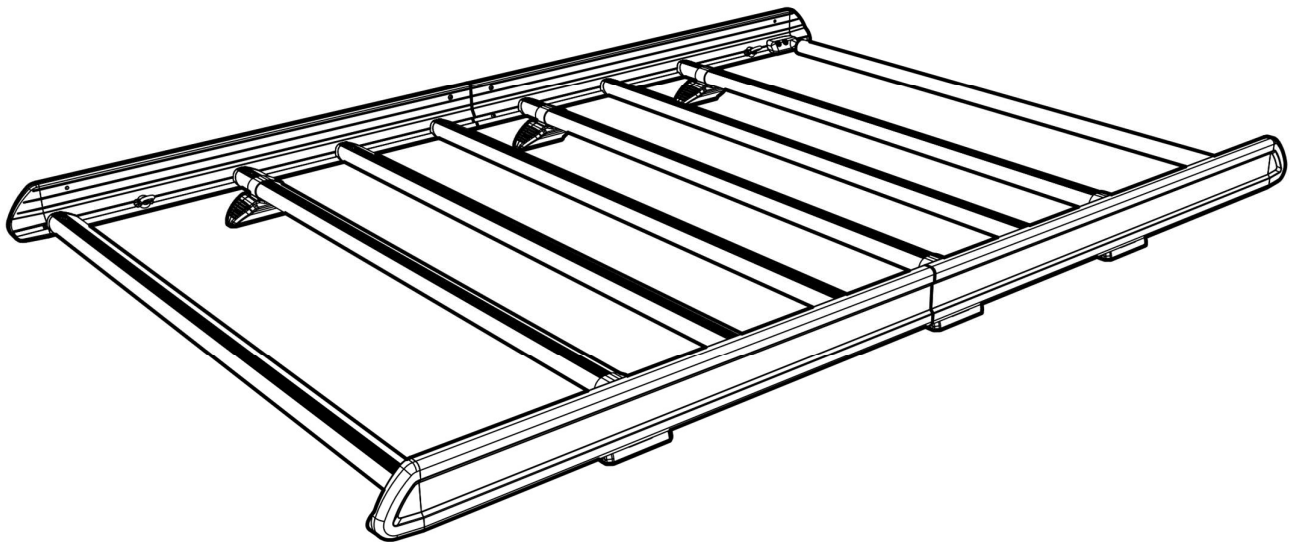

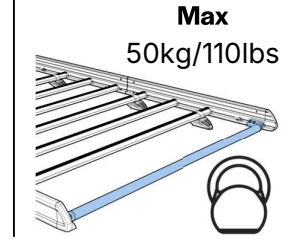
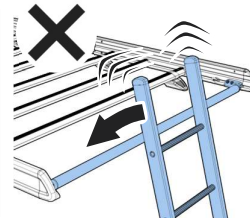

KammEdge.

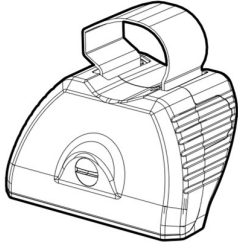

SA397U x 4

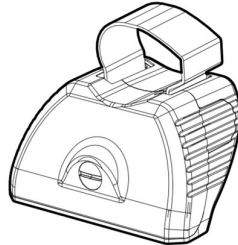

SA398U x 4

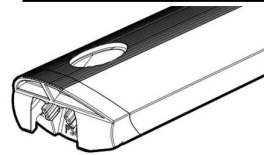

SA430/SA468 x 9

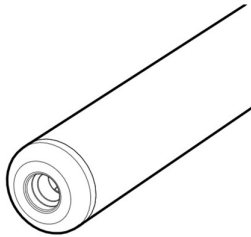

SA438 x 1

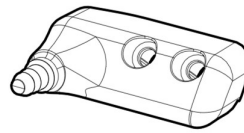

PS519 x 1

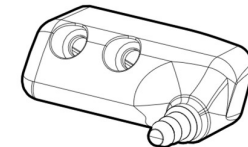

PS520 x 1

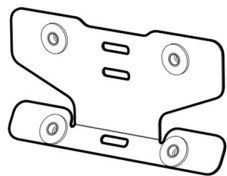

SA610 x 2/4

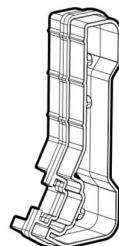

PS635 x 2/4

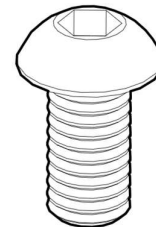

**FS323
(M6 x 16) x 8/16**

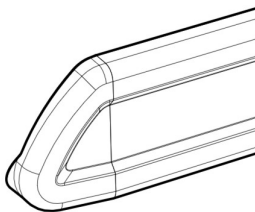

LSF (L) x 2

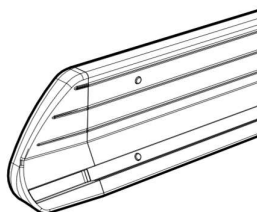

LSF (R) x 2

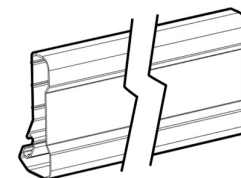

LSF (M) x 0/2



Fitting Kit

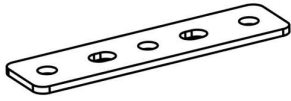

PS023 x 8

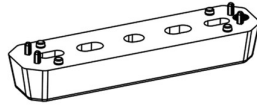

PS183 x 8

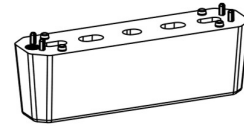

PS325 x 8

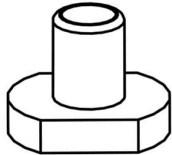

FN085 x 22



FN006 (M8) x 16

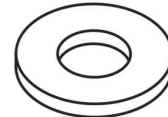

FW002 (M8) x 16



FS107
(M8 x 75) x 8



FS081
(M8 x 50) x 8

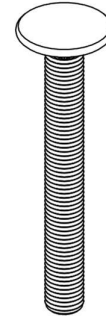

FS293
(M8 x 65) x 16



FT01 x 1



FT05 x 1

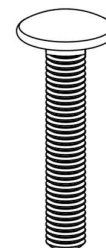

FS134
(M8 x 45) x 16

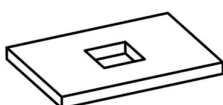

MS209 x 16



FS059
(M8 x 25) x 22



PS020 x 8



1.



2.

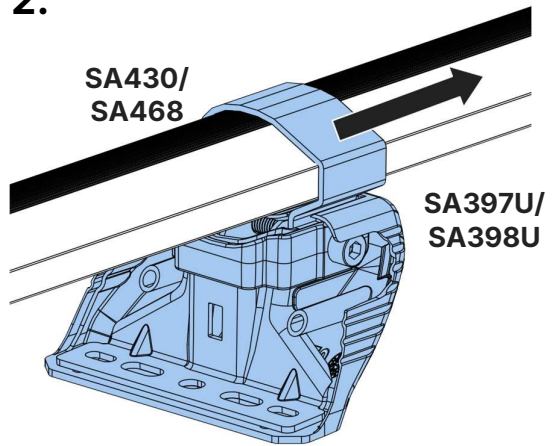

3a.



SA397U
PS183/PS325

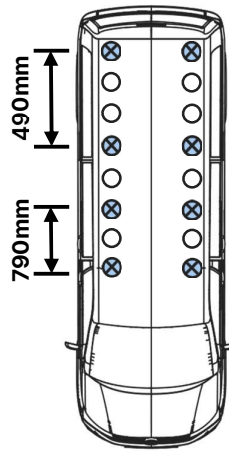

SA398U
PS183/PS325

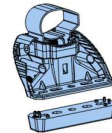

! SPRINTER/CRAFTER,
L2-H1, 2006-

3b.

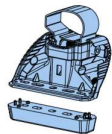

SA397U
PS183/PS325

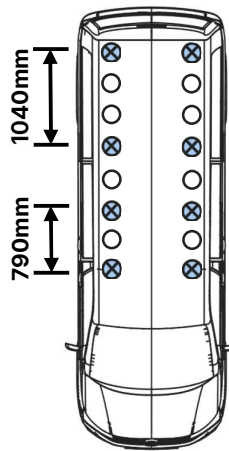

SA398U
PS183/PS325

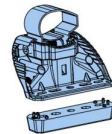

! SPRINTER/CRAFTER,
L2-H2, 2006-

4.

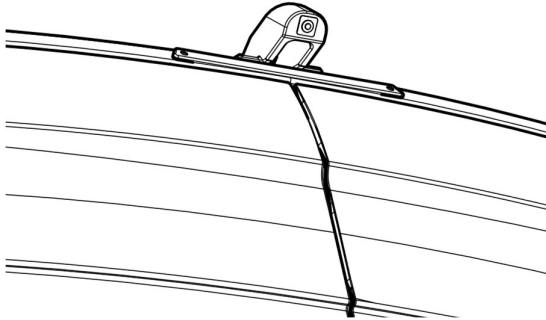
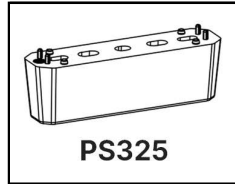

5.

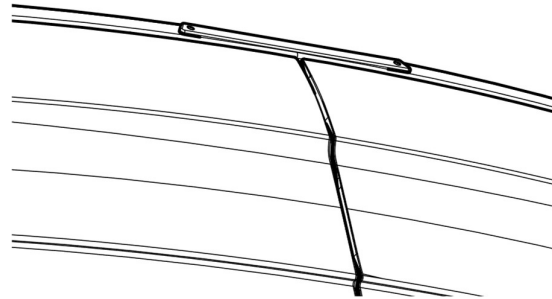
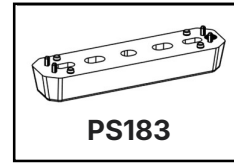

6a.

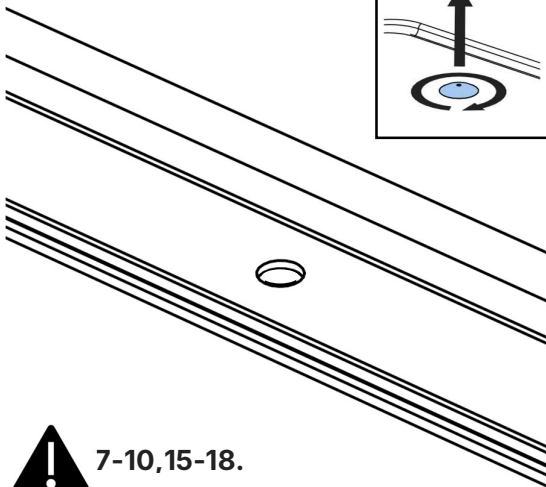
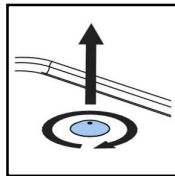

6b.

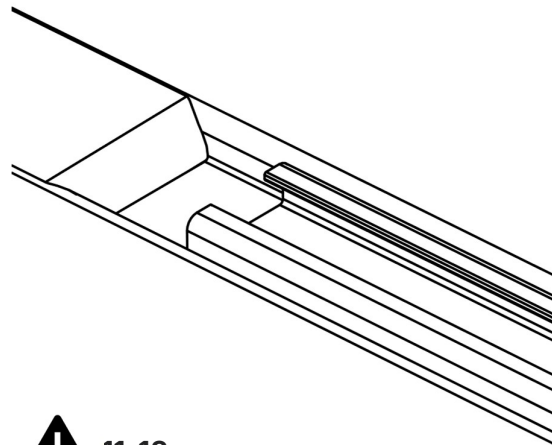

7.

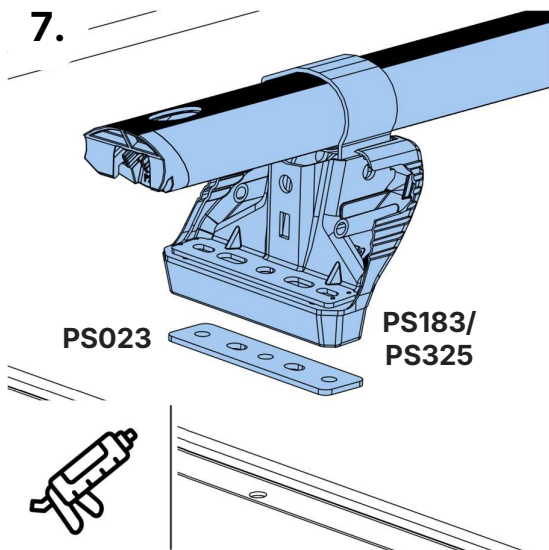

8.

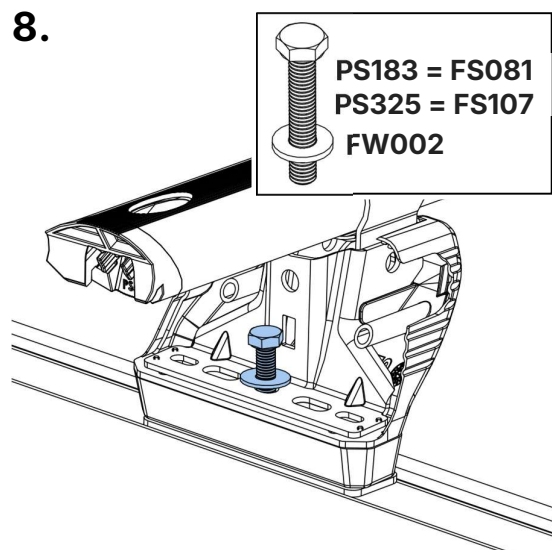

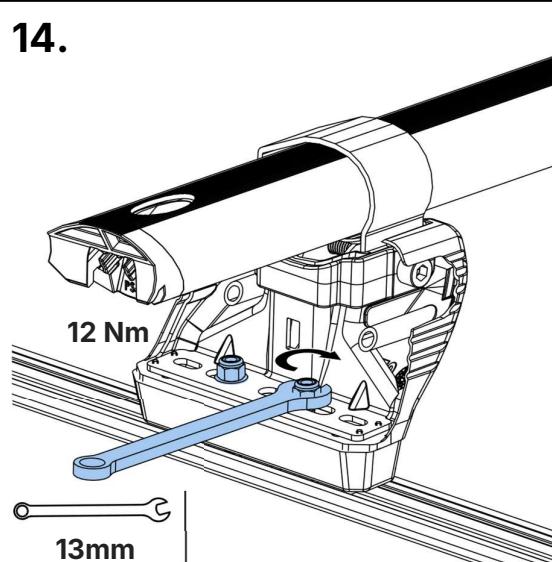
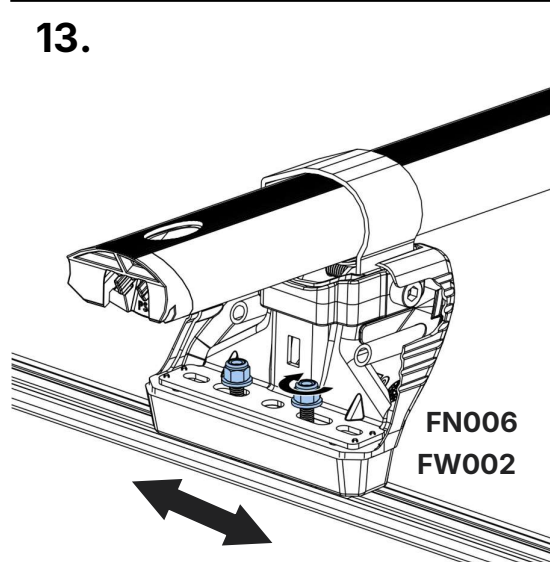
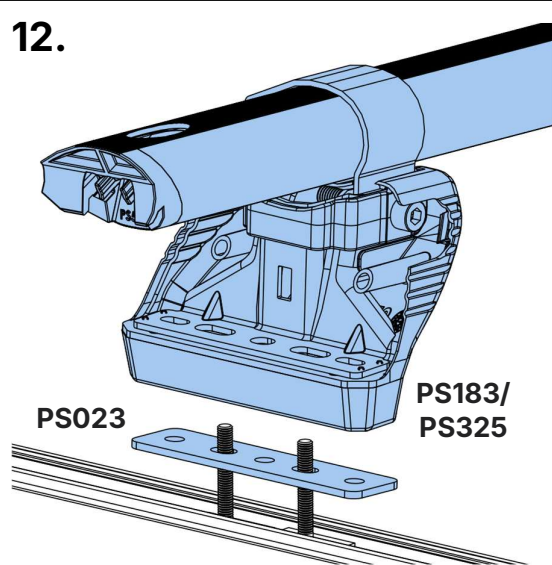
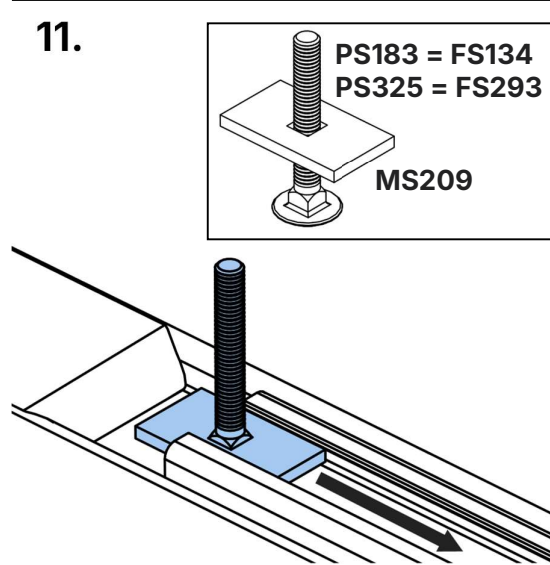
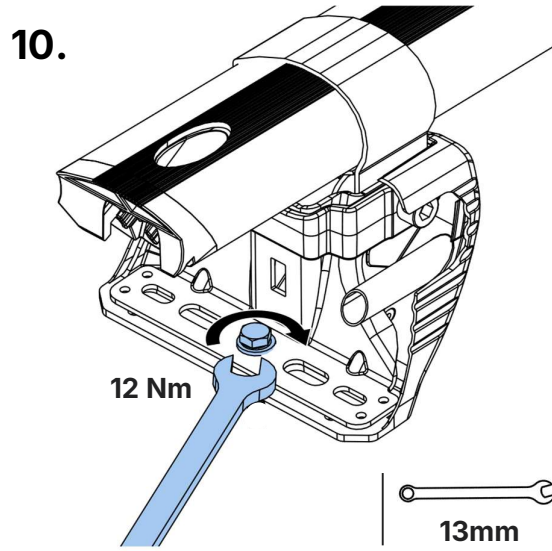
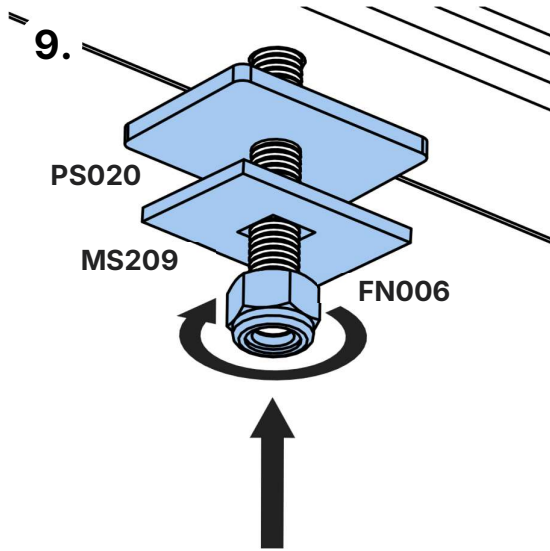

15.

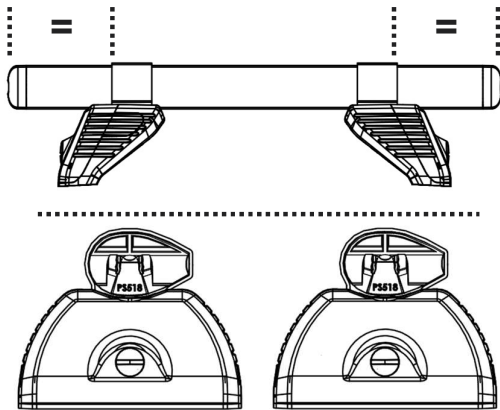

16.

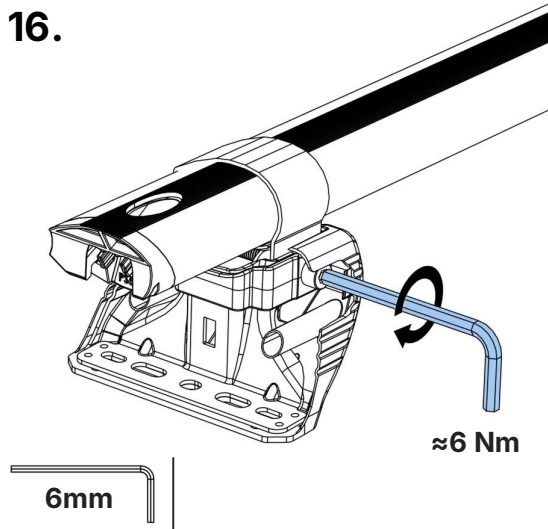

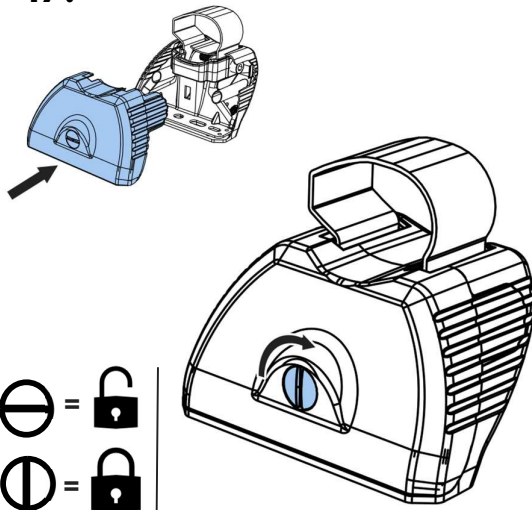

17.

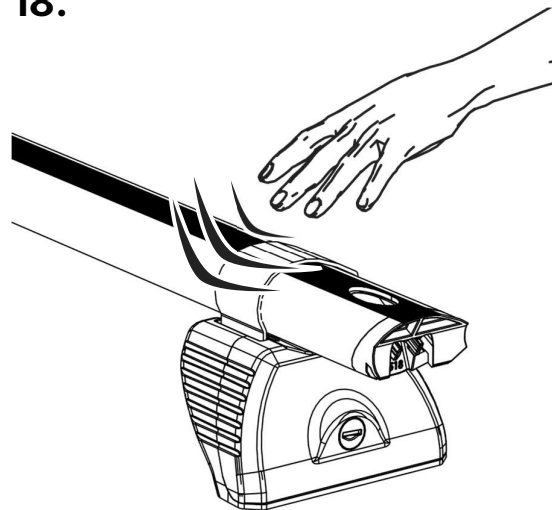

18.

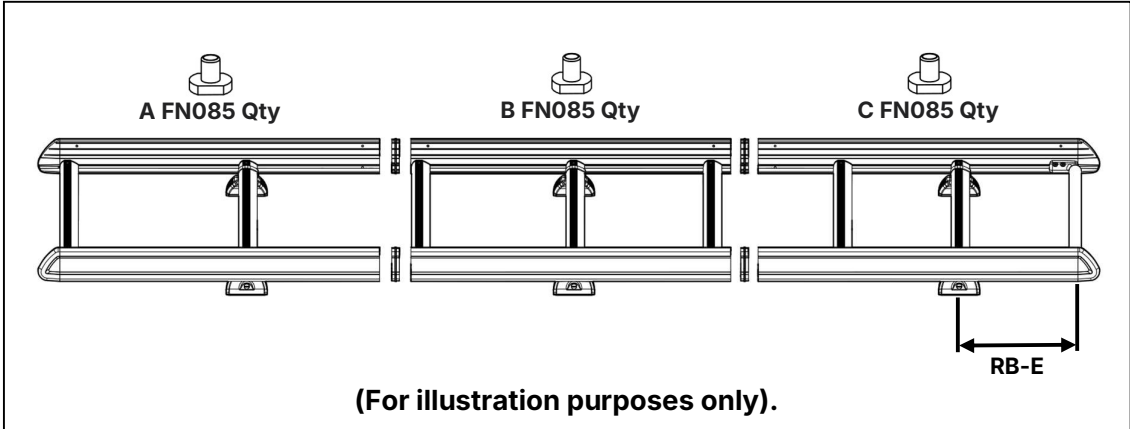

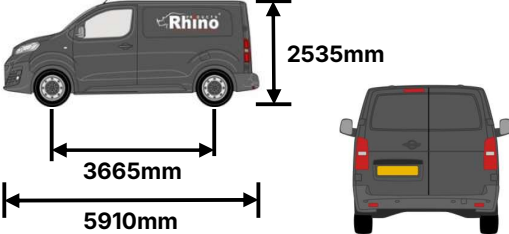

L519/LB519- Sprinter 2006-, L2-H1 (Twin)			
<p>Max Load = 150kg/330lbs</p>  <p>L519/LB519 = 34kg/74lbs</p>			
A FN085 Qty	B FN085 Qty	C FN085 Qty	Rear Bar – End (mm)
4	3	4	565
19-40, 54-64.			

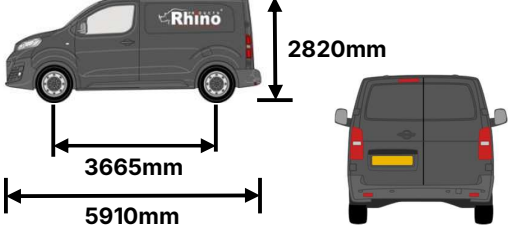
L520/LB520- Sprinter 2006-, L2-H2 (Twin)		
<p>Max Load = 150kg/330lbs</p>  <p>L520/LB520 = 31kg/68lbs</p>		
A FN085 Qty	B FN085 Qty	Rear Bar – End (mm)
5	6	490
19-23, 41-64.		

25.

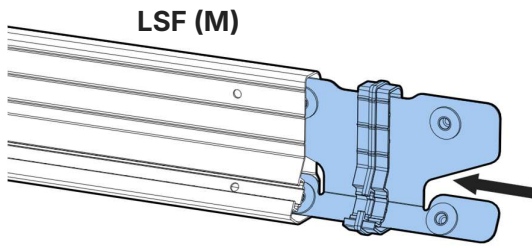

26.

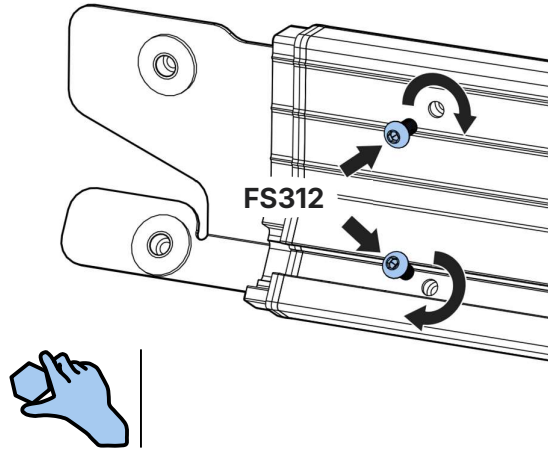

27.

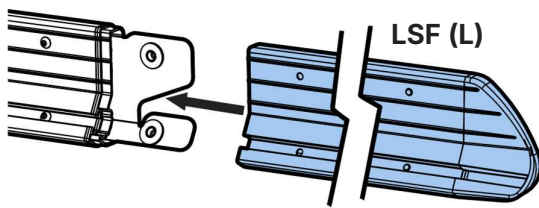

28.

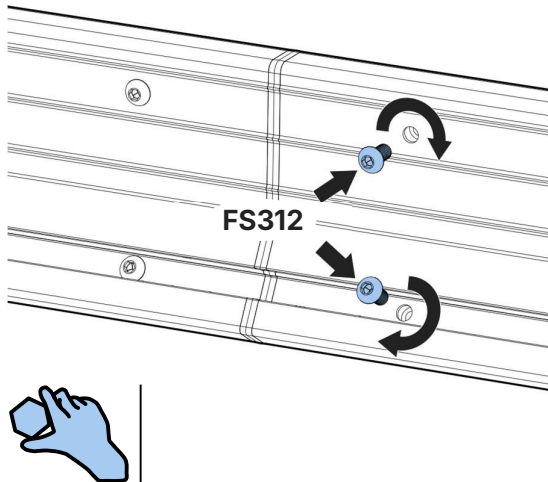

29.

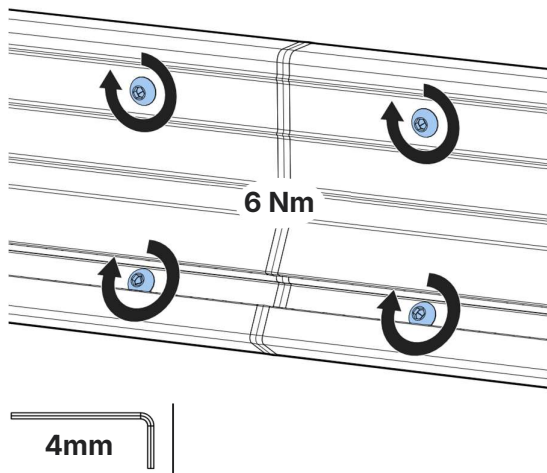

30.

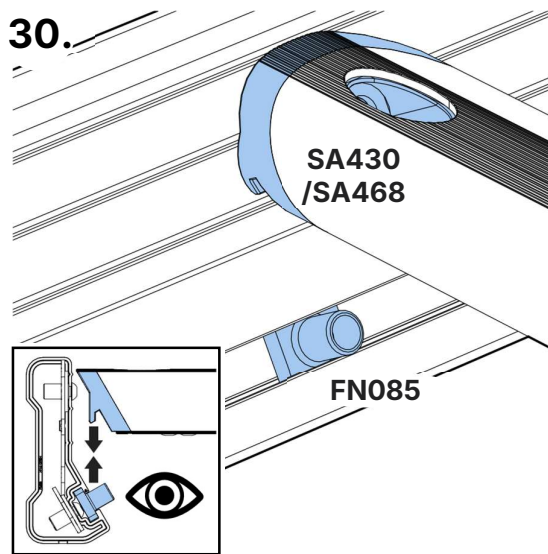

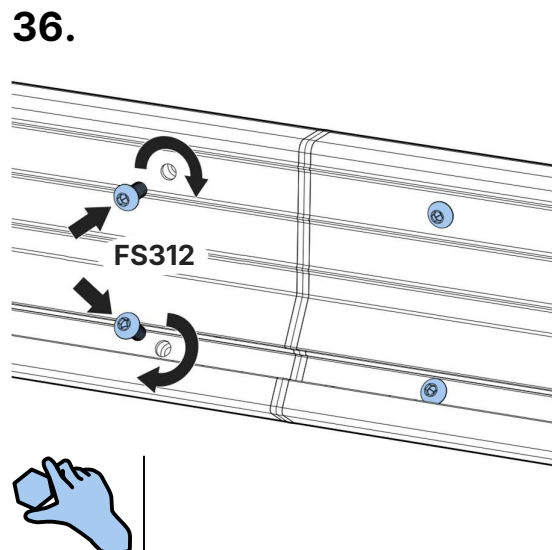
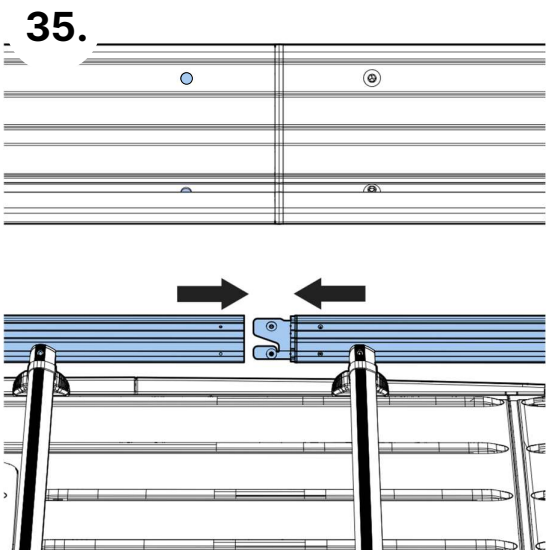
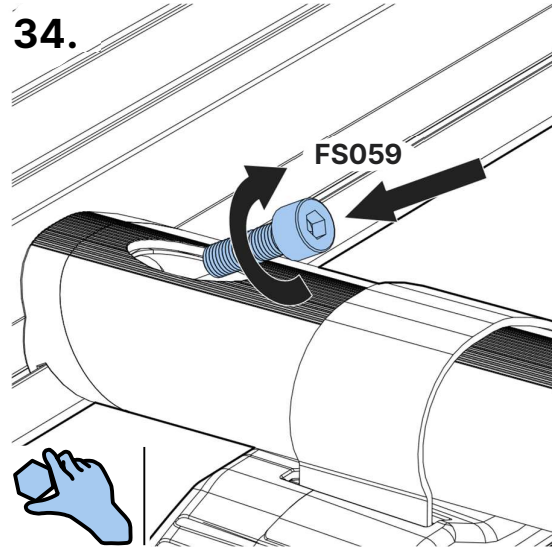
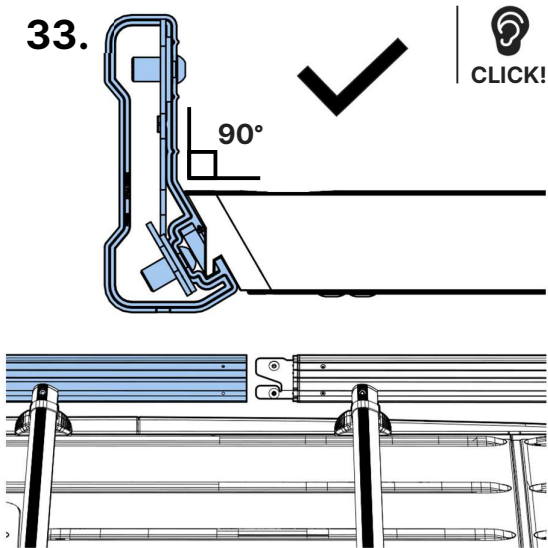
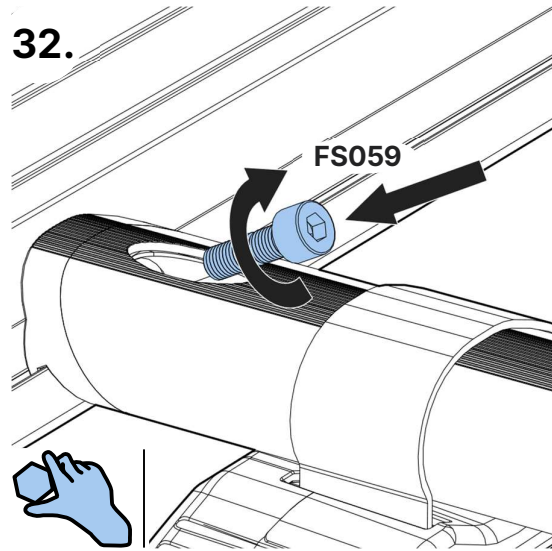
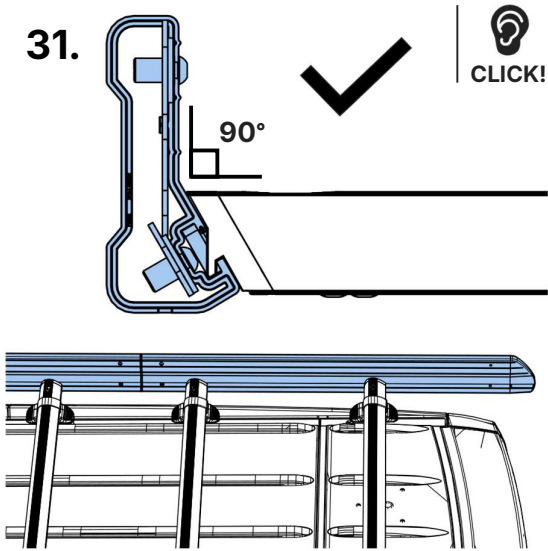

37.

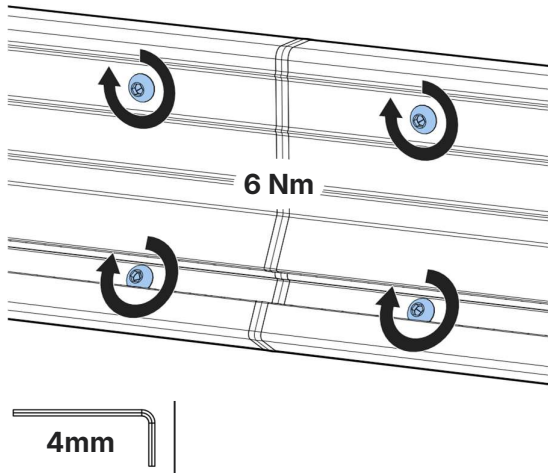

38.

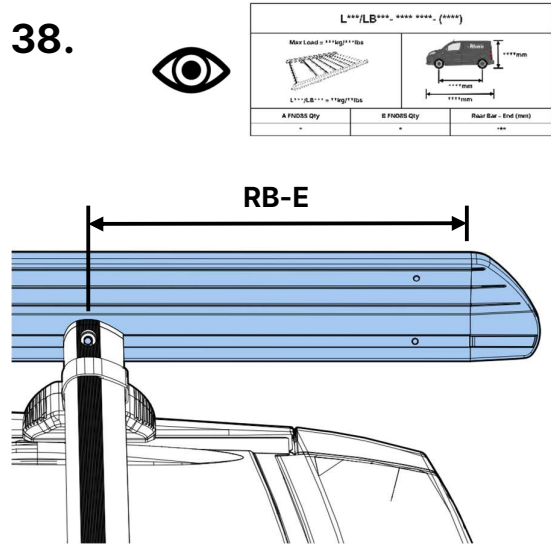

39.

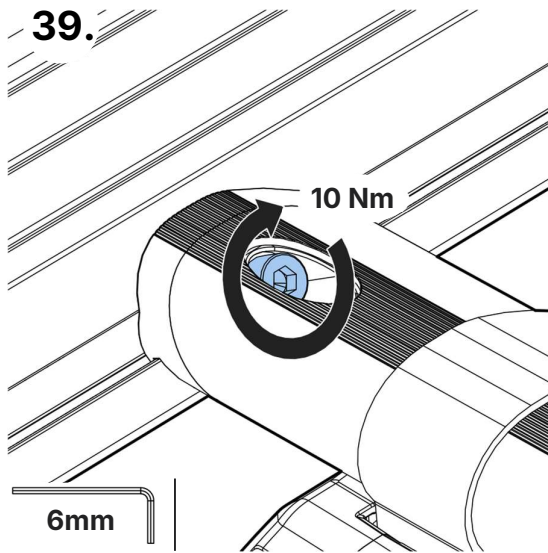

40.

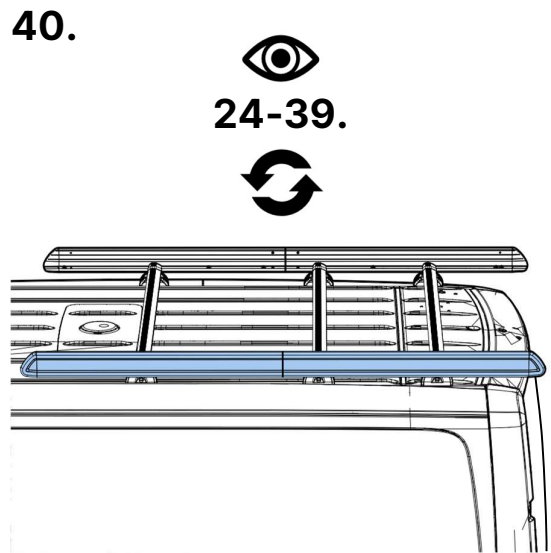

41.

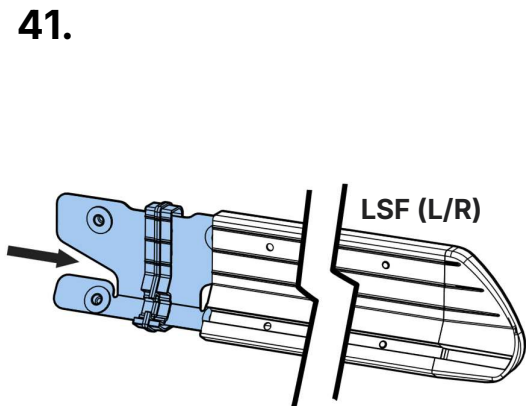

42.

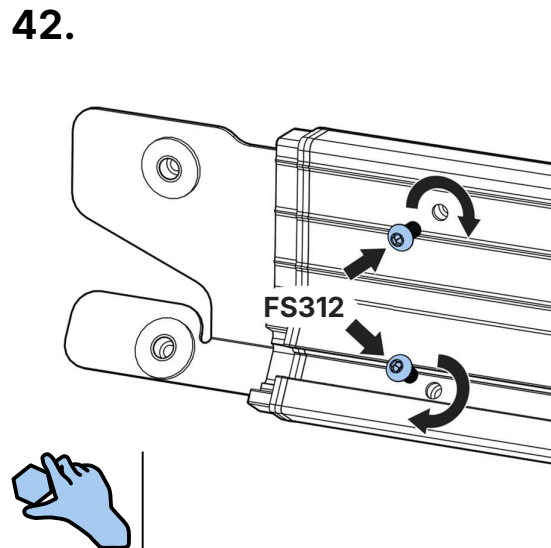

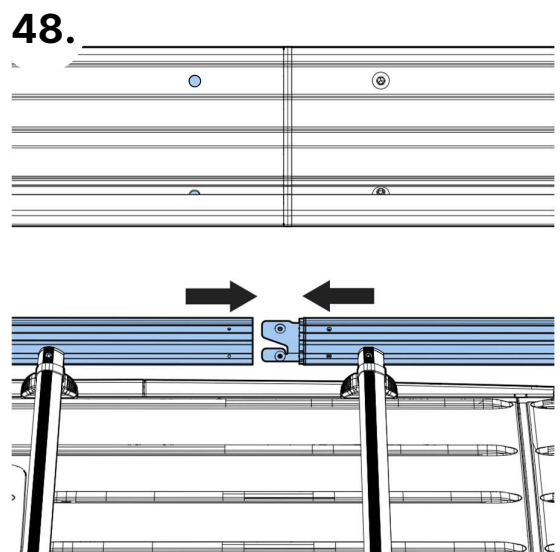
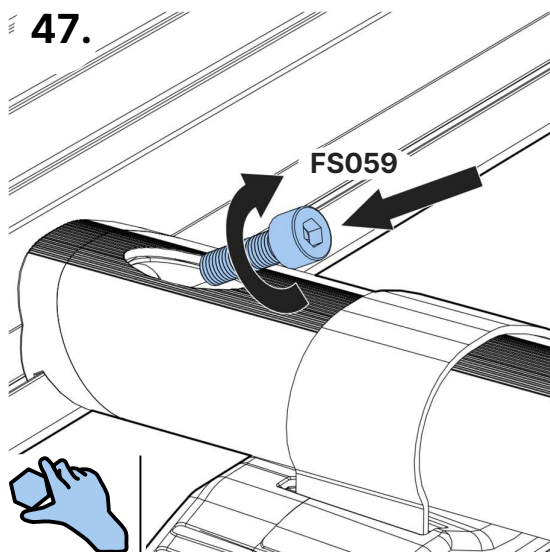
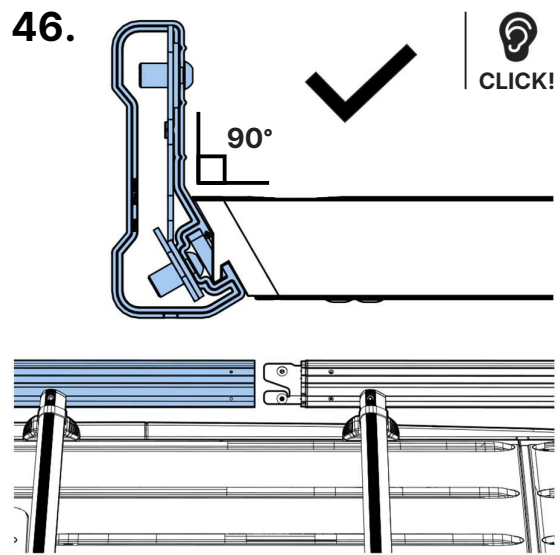
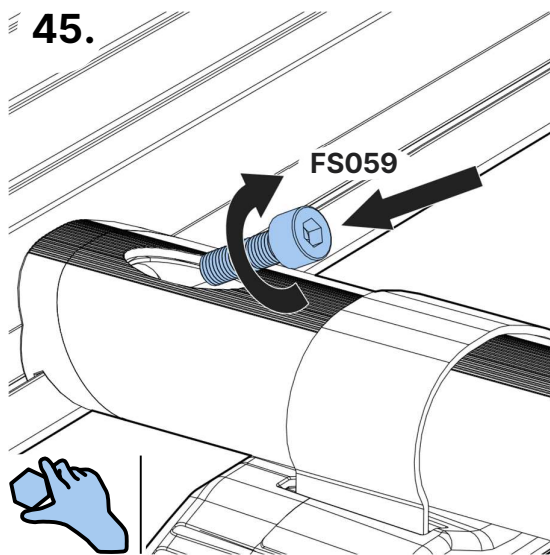
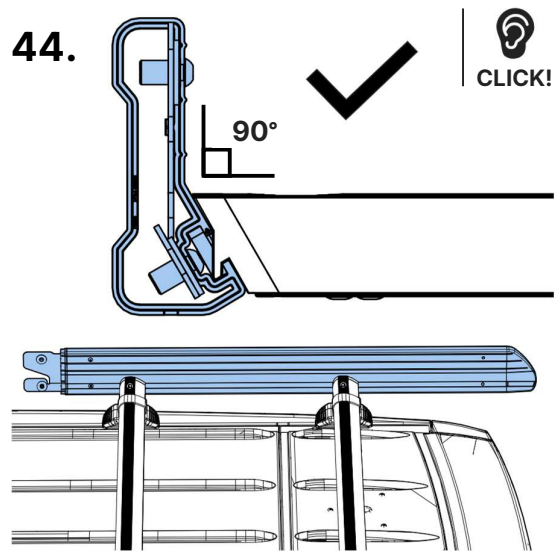
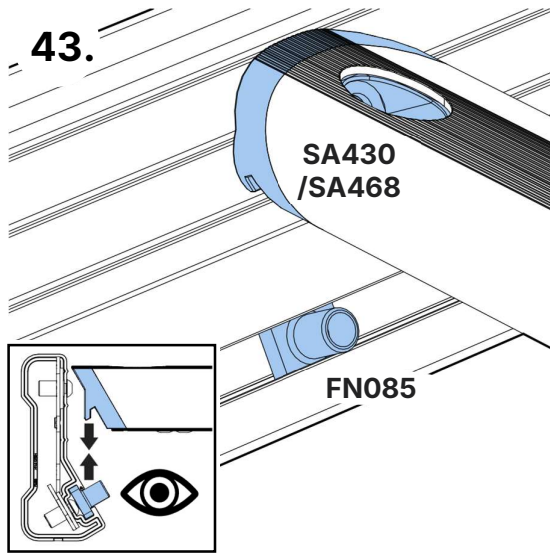

49.

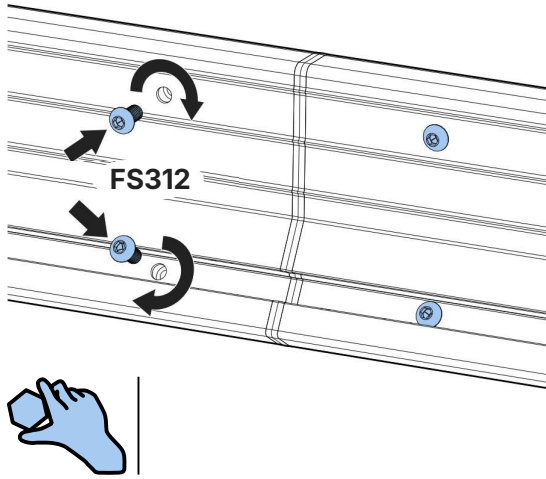

50.

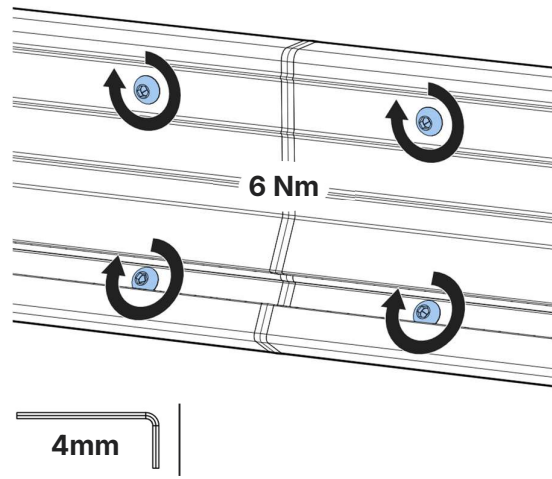

51.

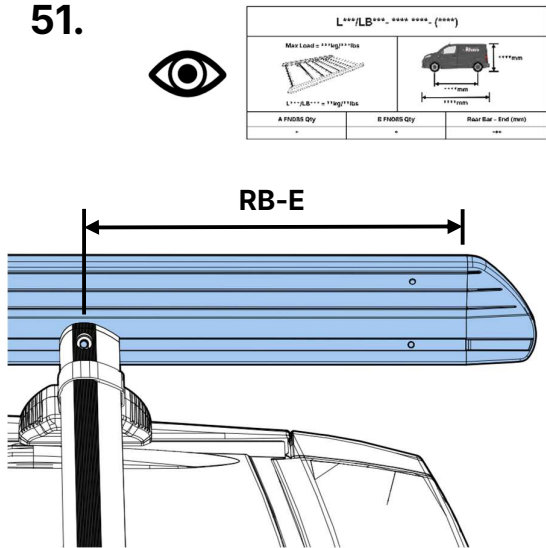

52.

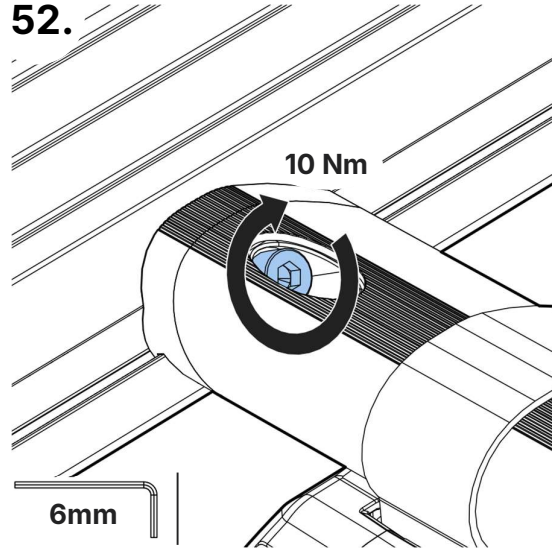

53.

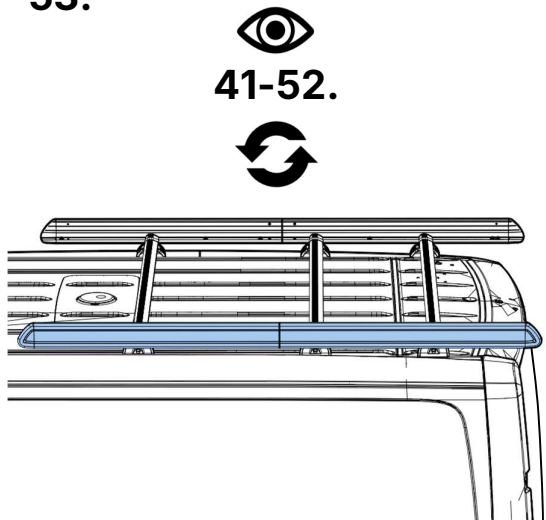

54.

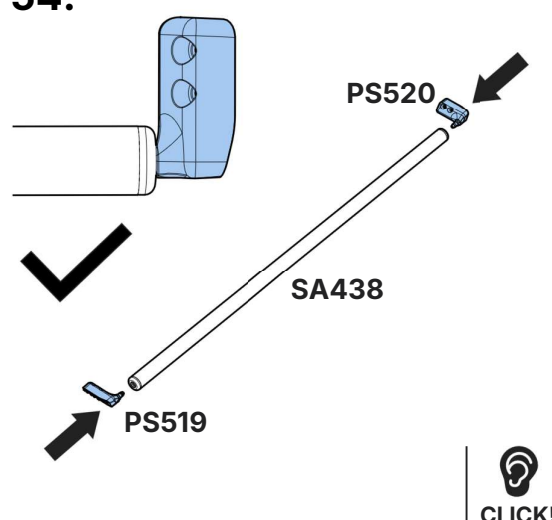

55.

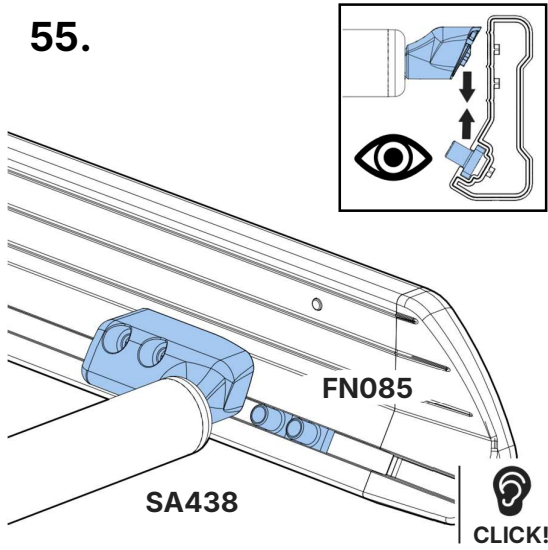

56.

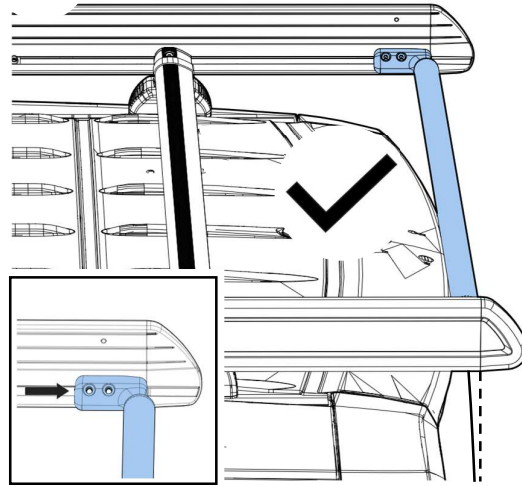

57.

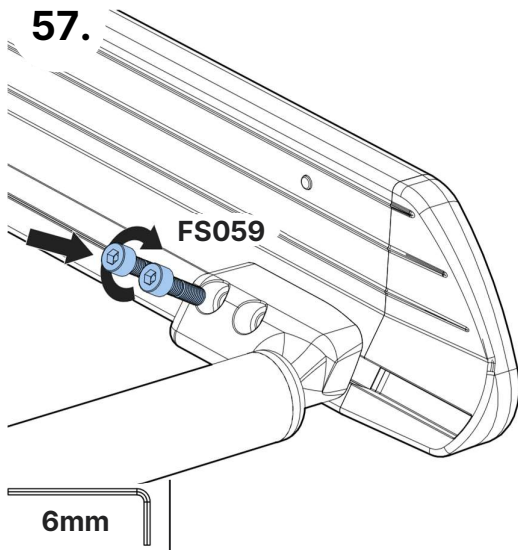

58.

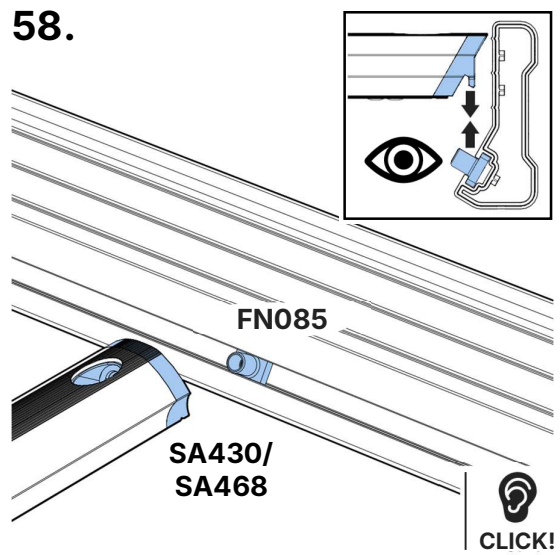

59.

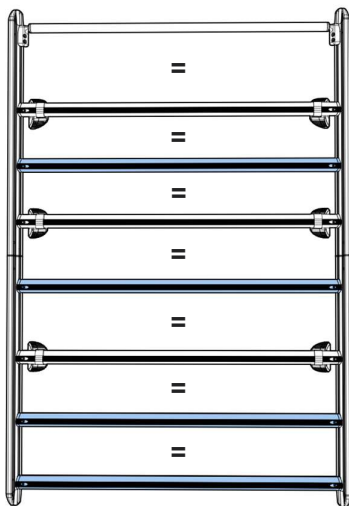

60.

