

Issue:	Drawn By:	Checked By:	CRF No.:	Date:	Description:
a	SJ	KB	3609	21/10/25	First Issue
b					
c					
d					

TB3KE

KammEdge.

Instructions

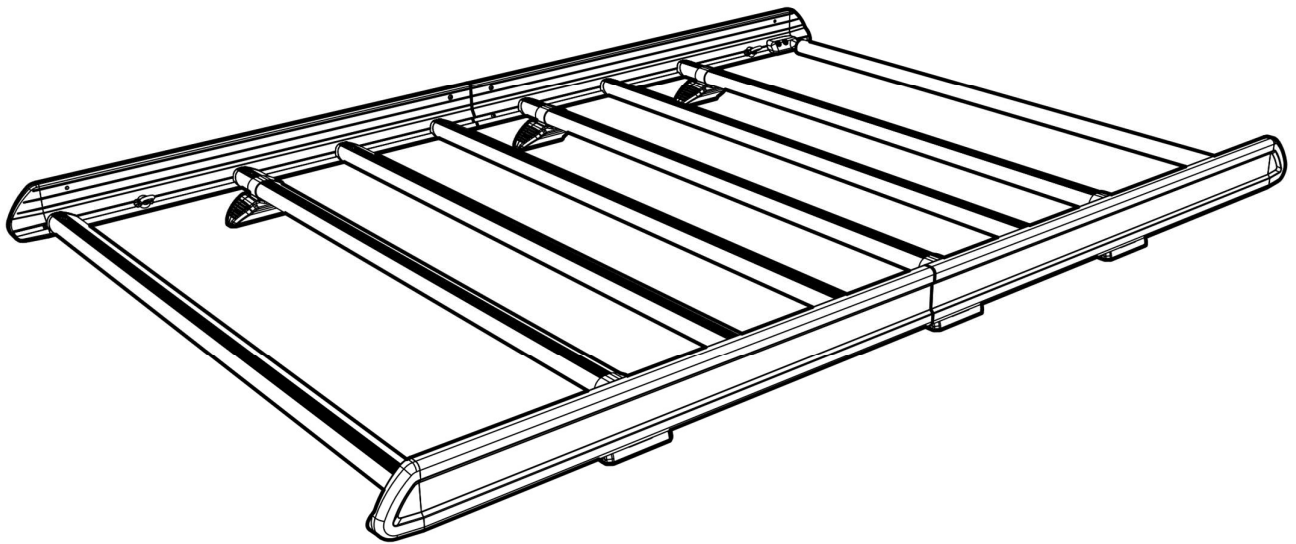

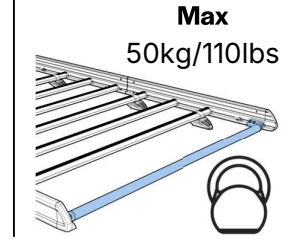

KammEdge.

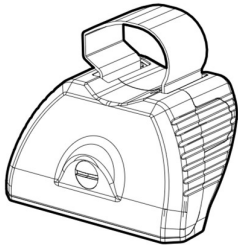

SA397U x 3

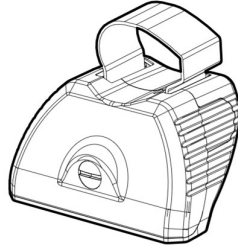

SA398U x 3



SA429/SA467 x 7



SA437 x 1

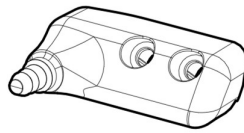

PS519 x 1

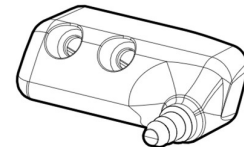

PS520 x 1

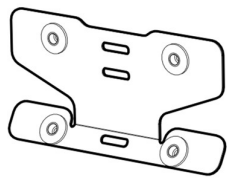

SA610 x 2

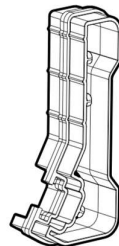

PS635 x 2

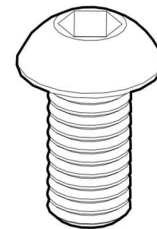

**FS323
(M6 x 16) x 8**

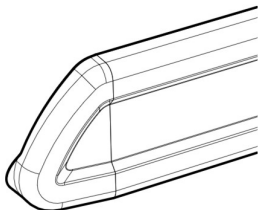

LSF (L) x 2

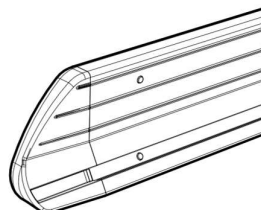

LSF (R) x 2



C04 x 6
optional upgrade

Fitting Kit

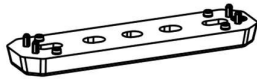

PS178 x 4

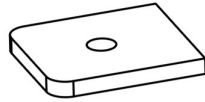

PS492 x 6

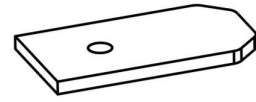

PS491 (3mm) x 6

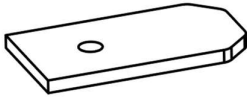

PS615 (8mm) x 8

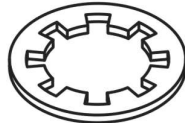

FW008 (M6) x 12

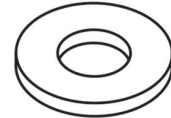

FW001 (M6) x 12

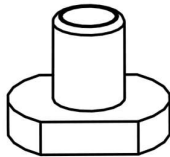

FN085 x 18



FT01 x 1

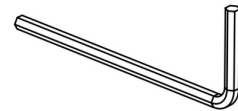

FT05 x 1



FS061
(M8 x 35) x 8



FS062
(M8 x 25) x 4



FS059
(M8 x 25) x 18



1.



2.

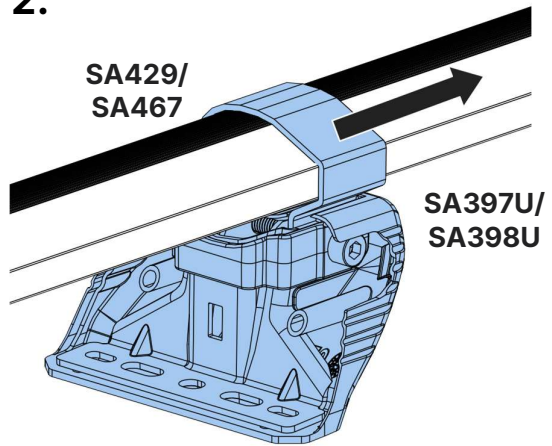

3.

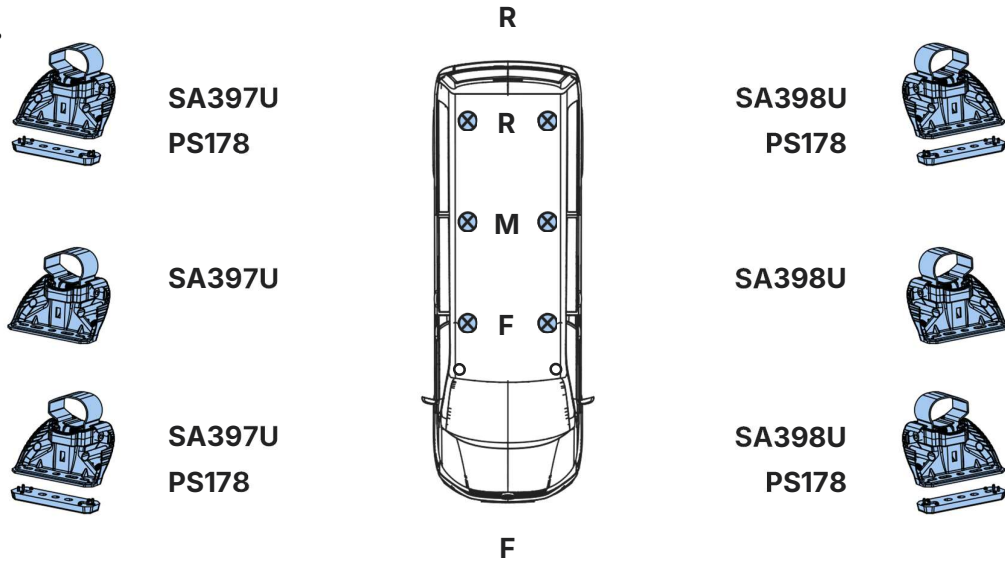

4.

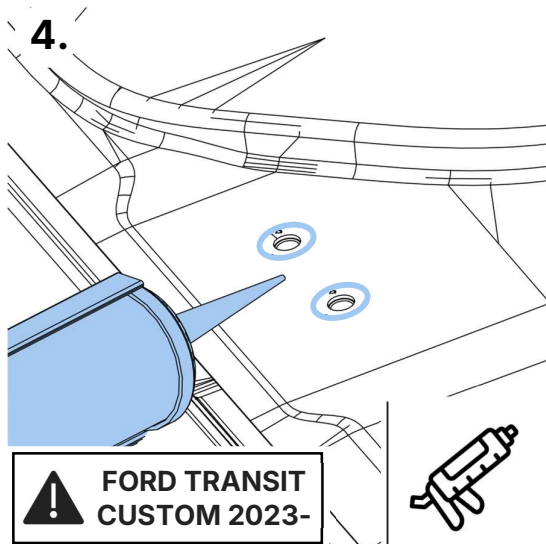

5a.

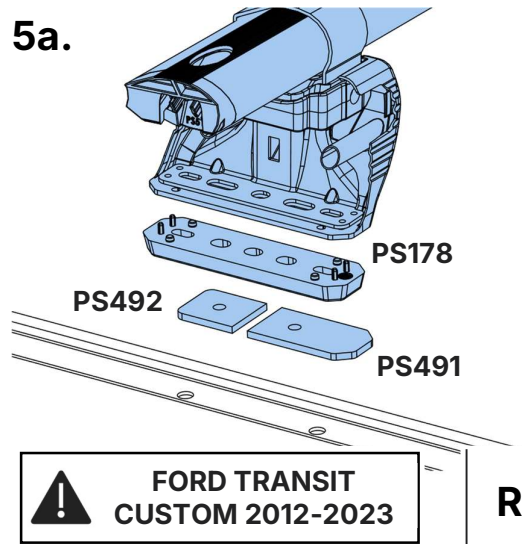

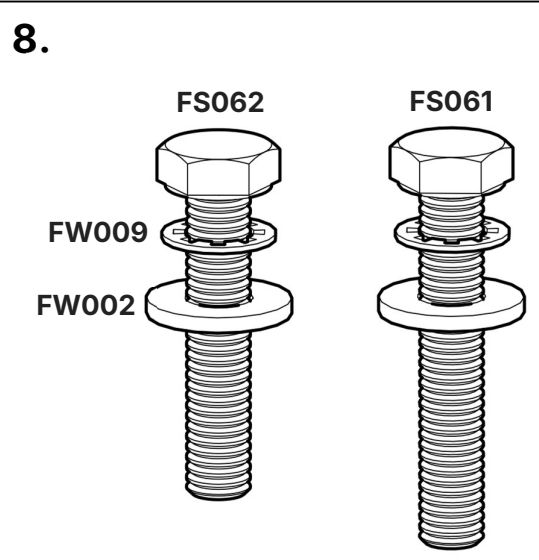
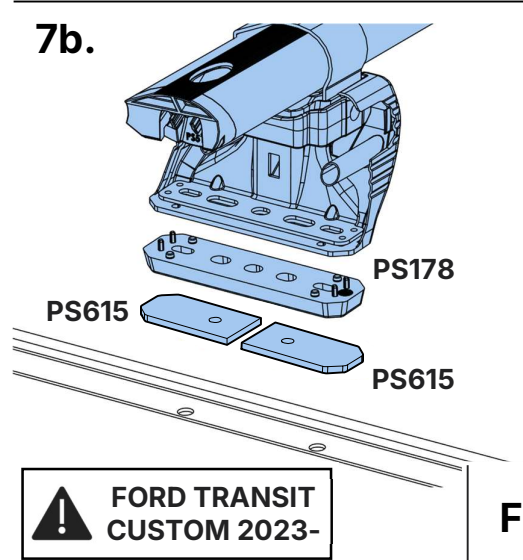
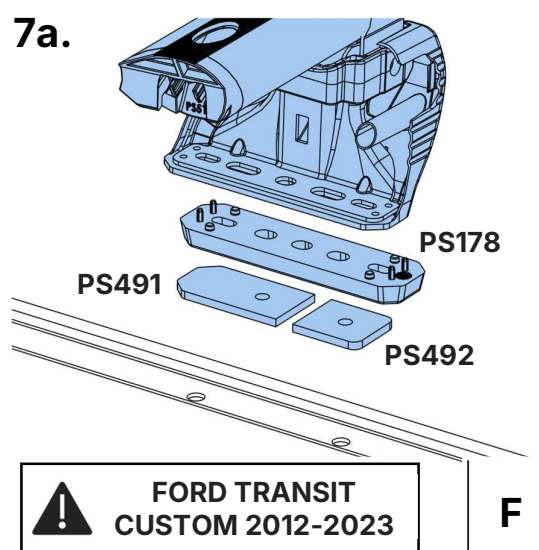
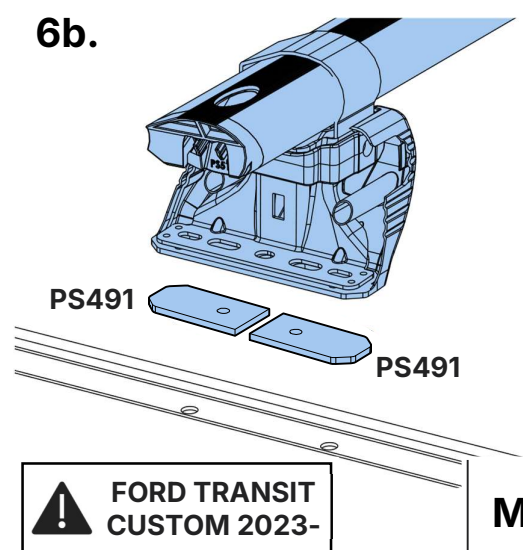
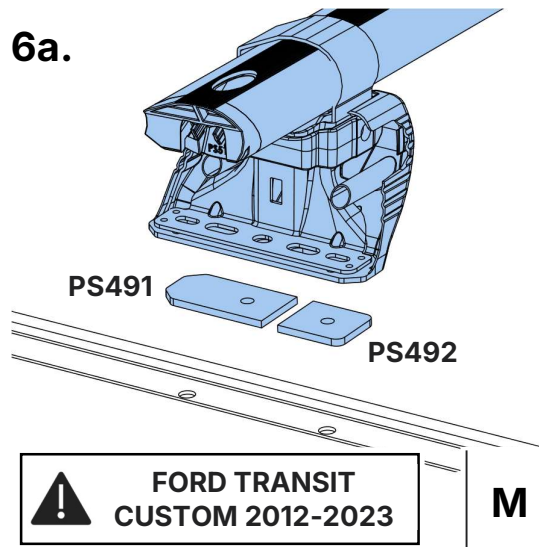
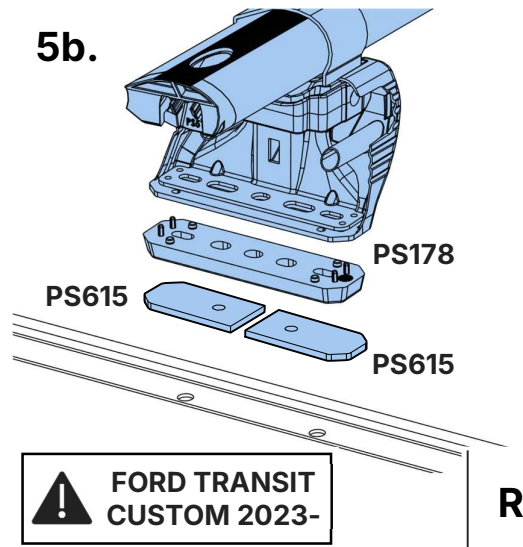

9.

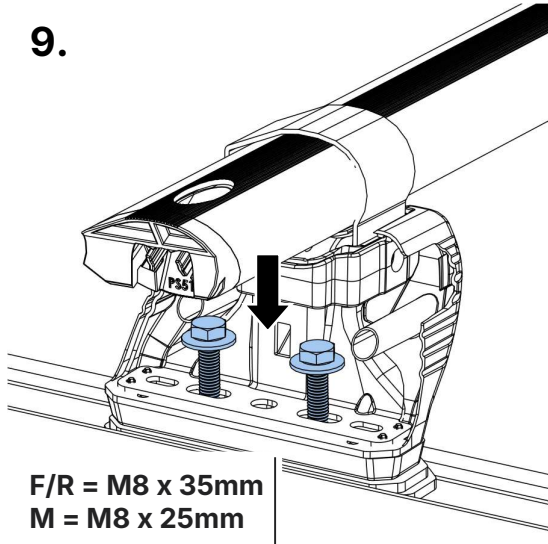

10.

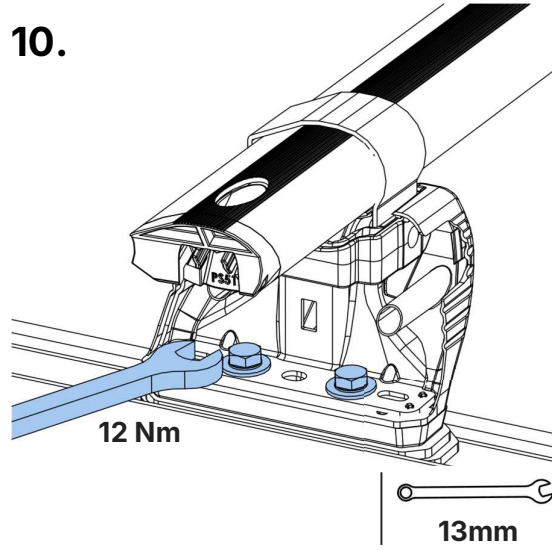

11.

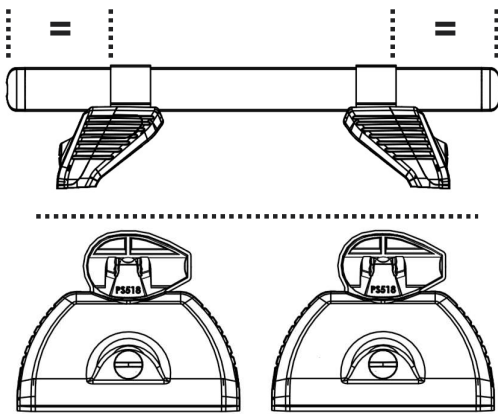

12.

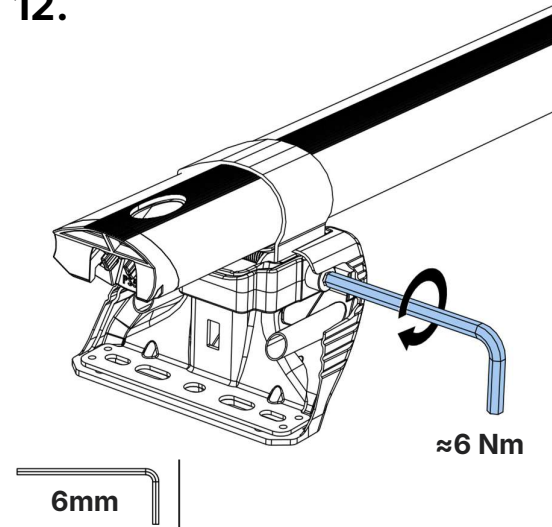

13.

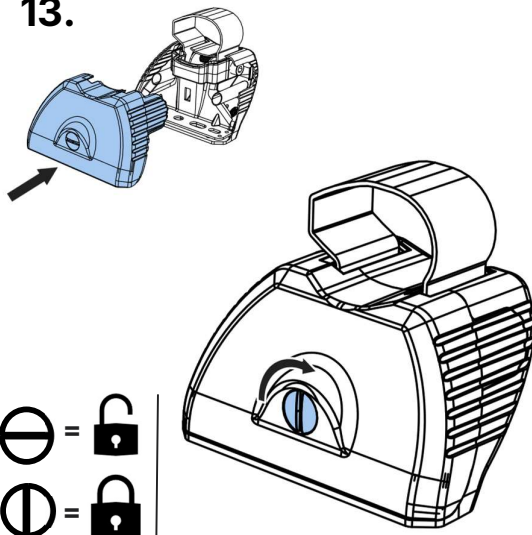

14.

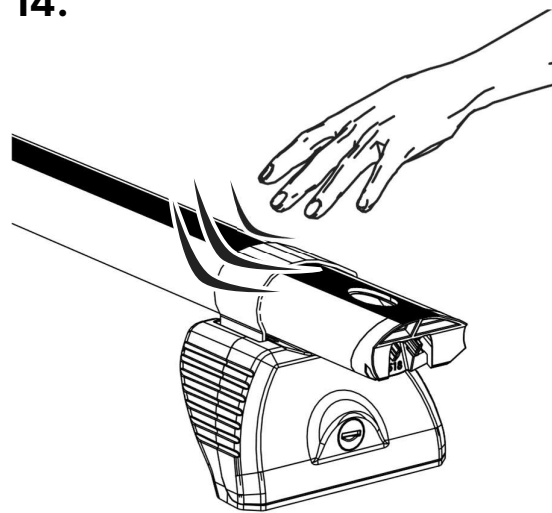

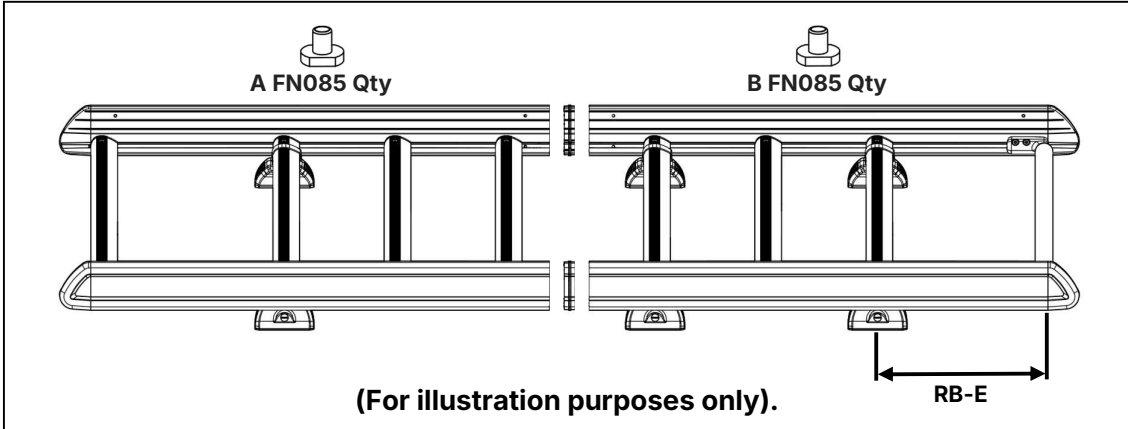

L615/LB615- Ford Transit Custom 2012-2023 – L1 (Twin)		
<p style="text-align: center;">Max Load = 150kg/330lbs</p> <p style="text-align: center;">L615/LB615 = 24kg/54lbs</p>	<p style="text-align: center;">1976mm 2933mm 4972mm</p>	
A FN085 Qty	B FN085 Qty	Rear Bar – End (mm)
4	5	370

L650/LB650- Ford Transit Custom 2012-2023 – L1 (Tailgate)		
<p style="text-align: center;">Max Load = 150kg/330lbs</p> <p style="text-align: center;">L650/LB650 = 24kg/54lbs</p>	<p style="text-align: center;">1976mm 2933mm 4972mm</p>	
A FN085 Qty	B FN085 Qty	Rear Bar – End (mm)
4	5	123

L616/LB616- Ford Transit Custom 2012-2023 – L2 (Twin)

Max Load = 150kg/330lbs

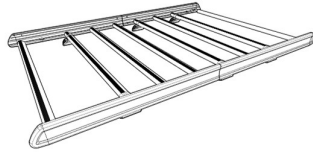

L616/LB616 = 25kg/55lbs

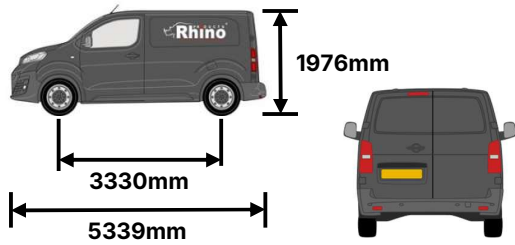

A FN085 Qty	B FN085 Qty	Rear Bar – End (mm)
3	6	30

L651/LB651- Ford Transit Custom 2012-2023 – L2 (Tailgate)

Max Load = 150kg/330lbs



L651/LB651 = 24kg/54lbs

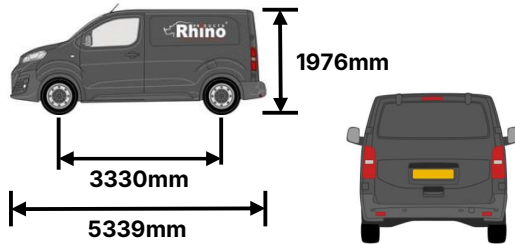

A FN085 Qty	B FN085 Qty	Rear Bar – End (mm)
3	6	121

L615/LB615- Ford Transit Custom 2023- L1 (Twin)

Max Load = 150kg/330lbs

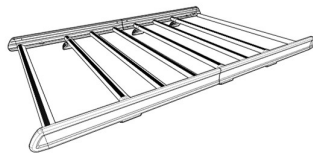

L615/LB615 = 24kg/54lbs

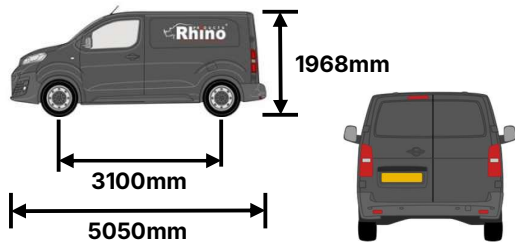

A FN085 Qty	B FN085 Qty	Rear Bar – End (mm)
4	5	370

L650/LB650- Ford Transit Custom 2023- L1 (Tailgate)

Max Load = 150kg/330lbs



L650/LB650 = 24kg/54lbs

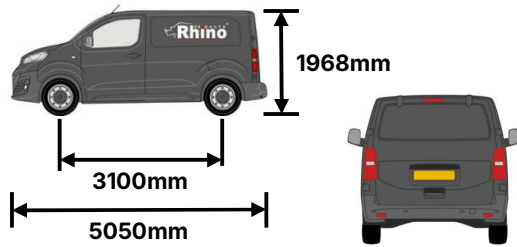

A FN085 Qty	B FN085 Qty	Rear Bar – End (mm)
3	6	150

L616/LB616- Ford Transit Custom 2023- L2 (Twin)

Max Load = 150kg/330lbs



L616/LB616 = 25kg/55lbs

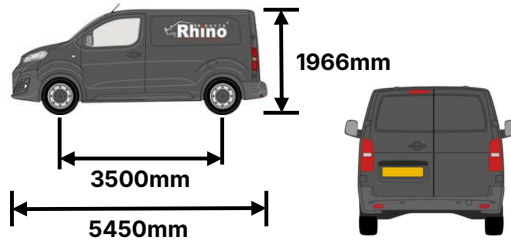

A FN085 Qty	B FN085 Qty	Rear Bar – End (mm)
4	5	350

L651/LB651- Ford Transit Custom 2023- L2 (Tailgate)

Max Load = 150kg/330lbs



L651/LB651 = 24kg/54lbs

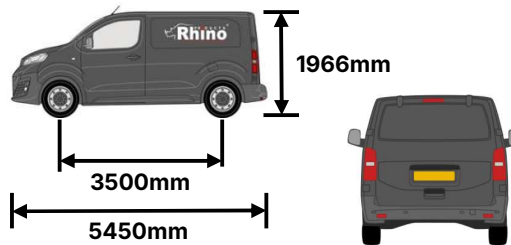

A FN085 Qty	B FN085 Qty	Rear Bar – End (mm)
3	6	130

21.

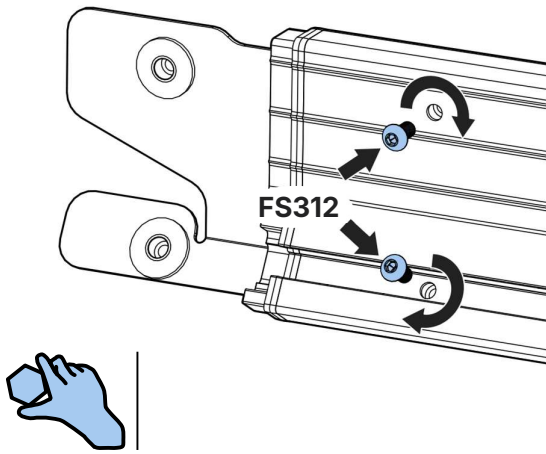

22.

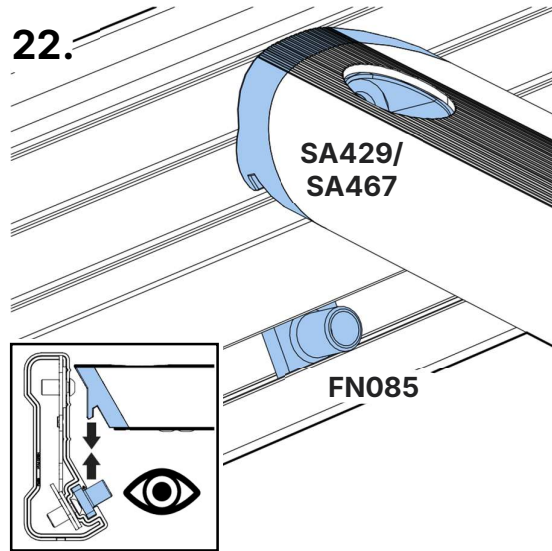

23.

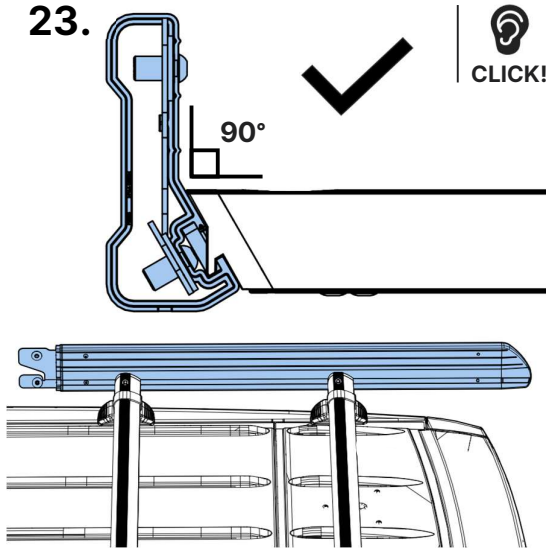

24.

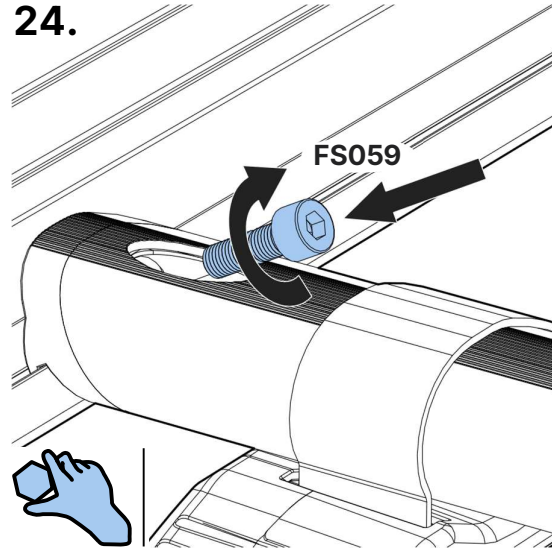

25.

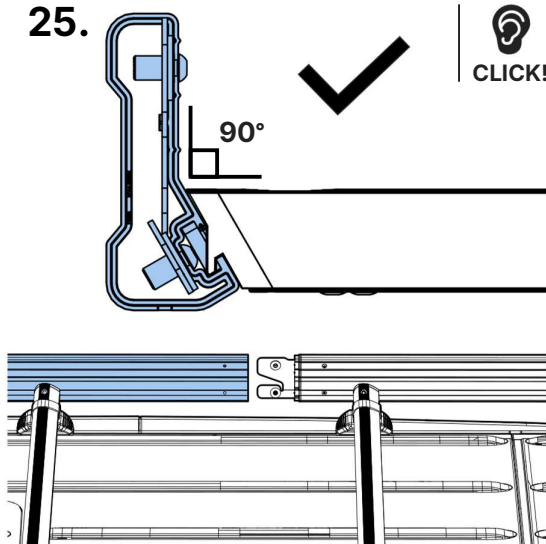

26.

