

Issue:	Drawn By:	Checked By:	CRF No.:	Date:	Description:
a	SJ	KB	3609	21/10/25	First Issue
b					
c					
d					

VF4KE

KammEdge.

Instructions

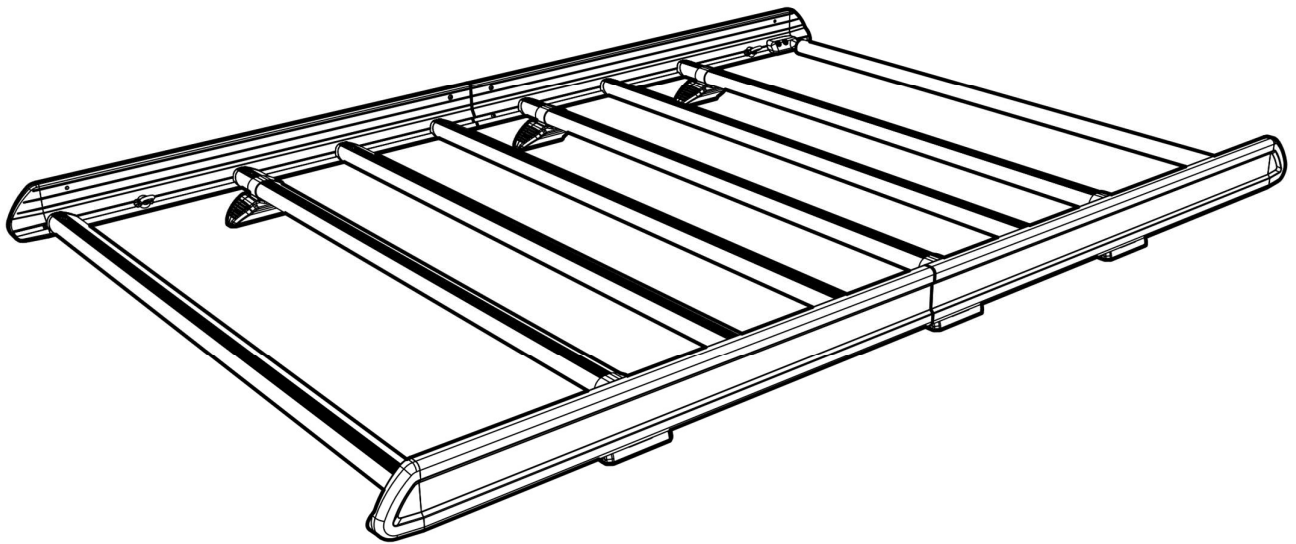

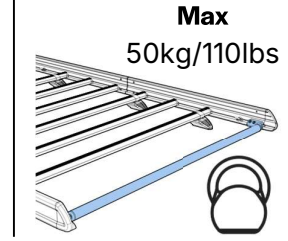
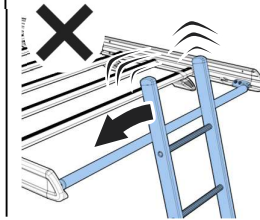
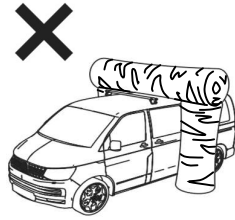

KammEdge.

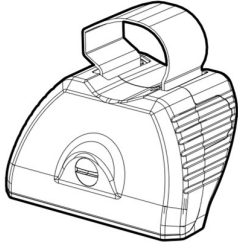

SA397U x 4

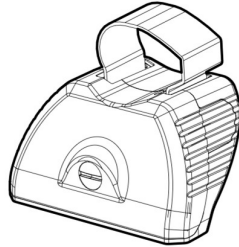

SA398U x 4

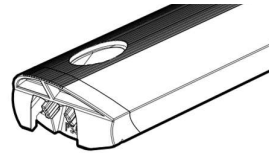

SA430/SA468 x 10

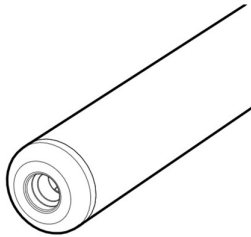

SA438 x 1

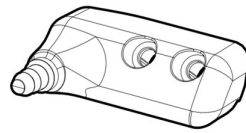

PS519 x 1

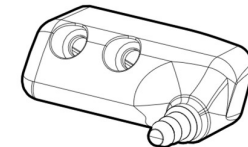

PS520 x 1

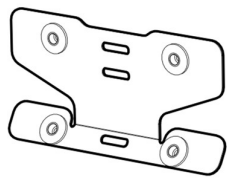

SA610 x 4

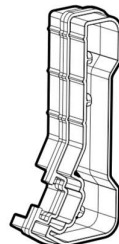

PS635 x 4

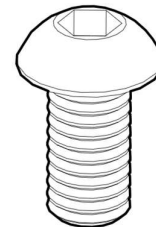

**FS323
(M6 x 16) x 16**

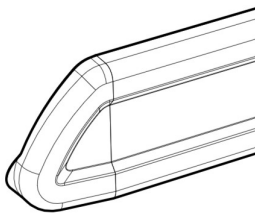

LSF (L) x 2

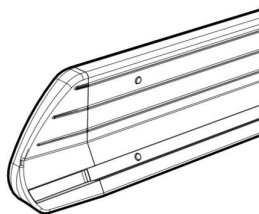

LSF (R) x 2

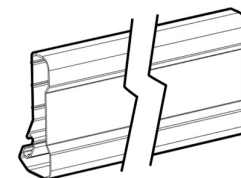

LSF (M) x 2



Fitting Kit

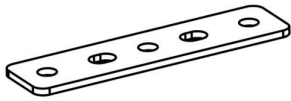

PS023 x 8

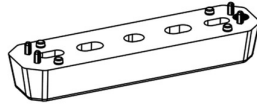

PS183 x 8

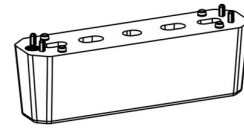

PS325 x 2

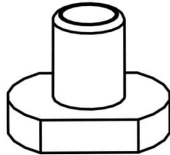

FN085 x 24

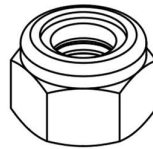

FN006 (M8) x 16

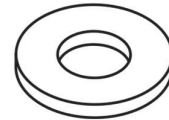

FW002 (M8) x 16

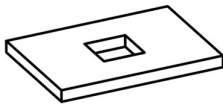

MS209 x 16



PS020 x 8

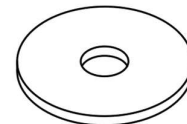

PS0208 (M8) x 8



FT01 x 1

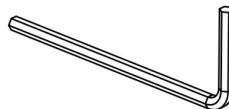

FT05 x 1



FS059
(M8 x 25) x 24

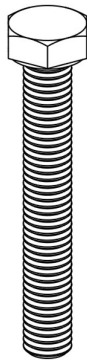

FS107
(M8 x 75) x 2



FS081
(M8 x 50) x 6

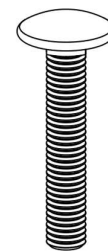

FS134
(M8 x 45) x 16



L4 = A

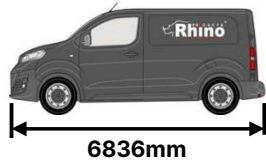

L4 = C (T-Track)

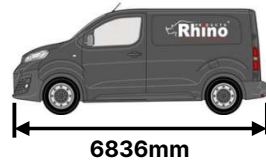

L5 = B

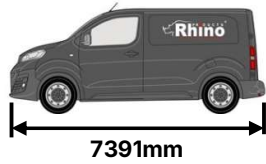

L5 = D (T-Track)

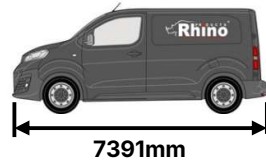

1a.

A/B

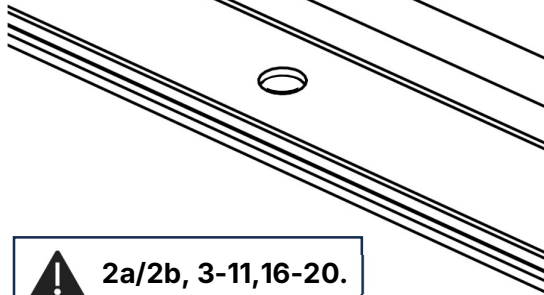
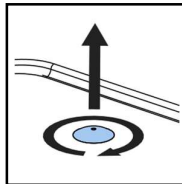

⚠ 2a/2b, 3-11,16-20.

1b.

C/D

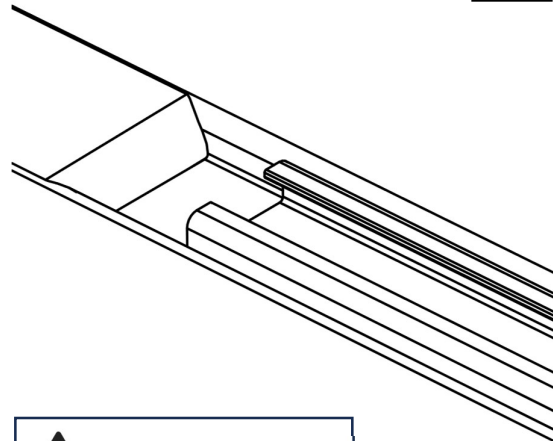

⚠ 2c/2d, 3-4,12-20.

2a.

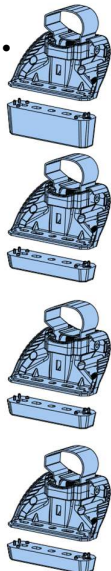

SA397U
PS325
SA397U
PS183
SA397U
PS183
SA397U
PS183

R

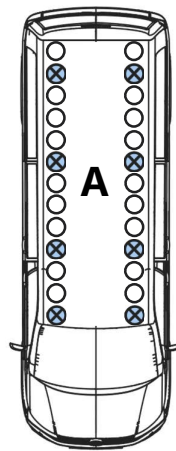

F

SA398U
PS325
SA398U
PS183
SA398U
PS183
SA398U
PS183

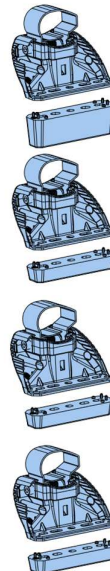

2b.

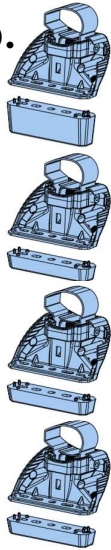

SA397U
PS325

SA397U
PS183

SA397U
PS183

SA397U
PS183

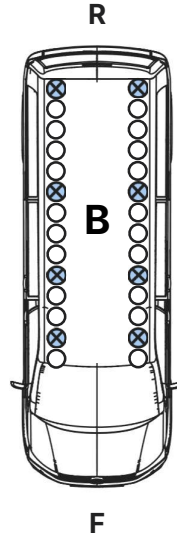

SA398U
PS325

SA398U
PS183

SA398U
PS183

SA398U
PS183



2c.

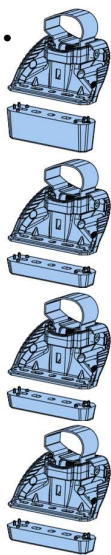

SA397U
PS325

SA397U
PS183

SA397U
PS183

SA397U
PS183

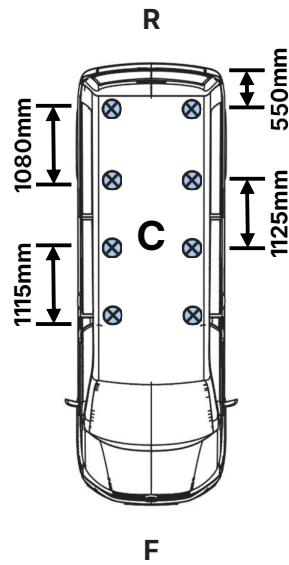

SA398U
PS325

SA398U
PS183

SA398U
PS183

SA398U
PS183



2d.

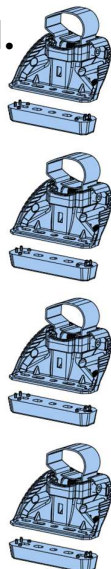

SA397U
PS183

SA397U
PS183

SA397U
PS183

SA397U
PS183

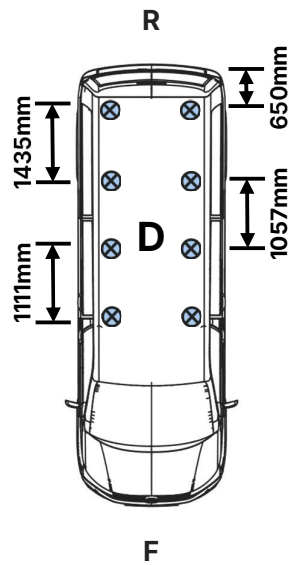

SA398U
PS183

SA398U
PS183

SA398U
PS183

SA398U
PS183

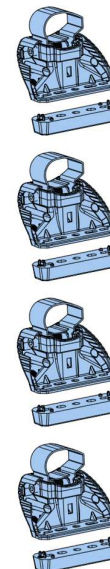

3.

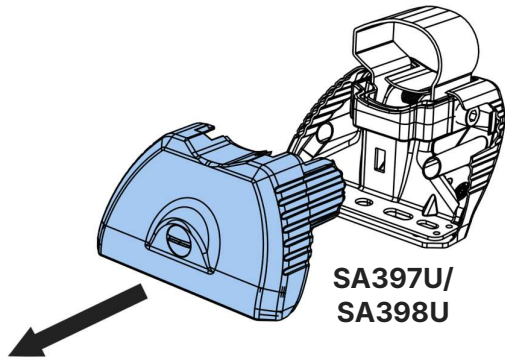

4.

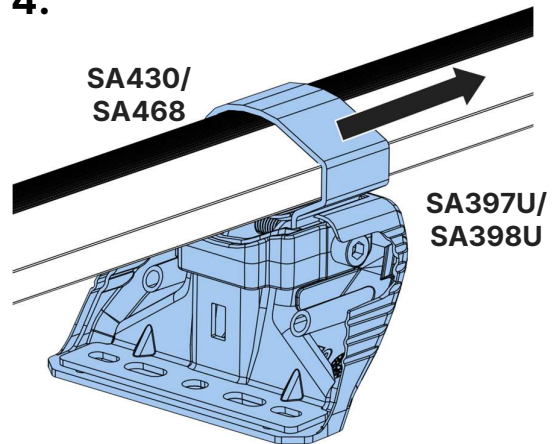

5.

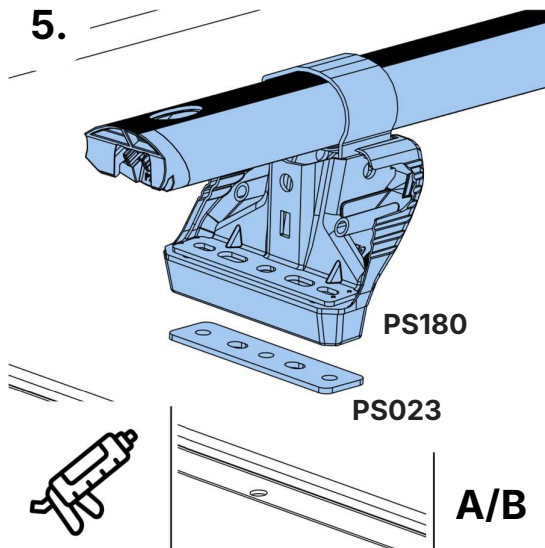

6.

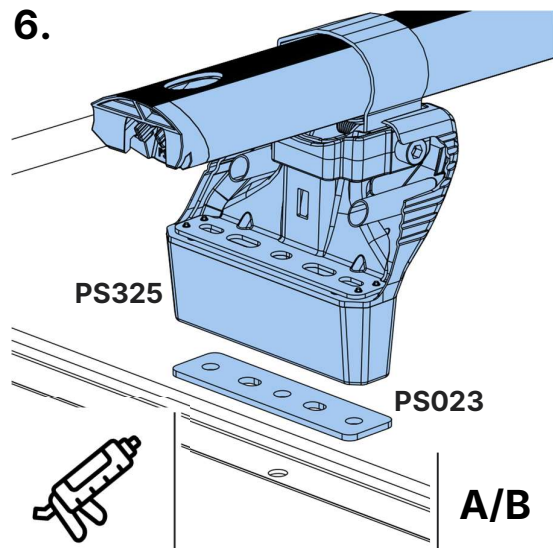

7.

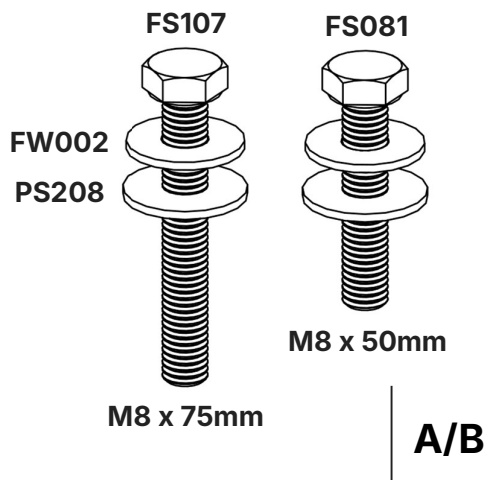

8.

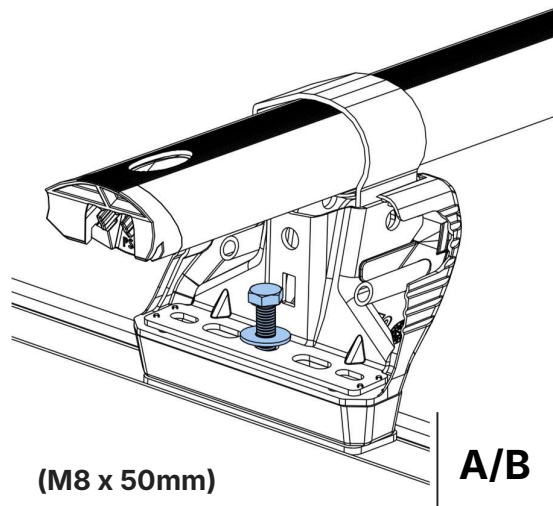

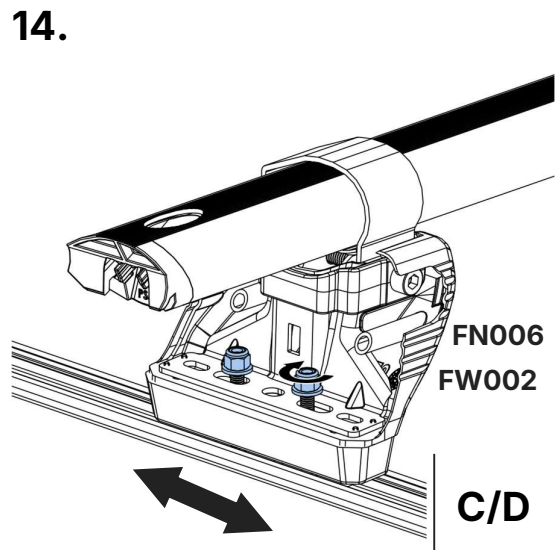
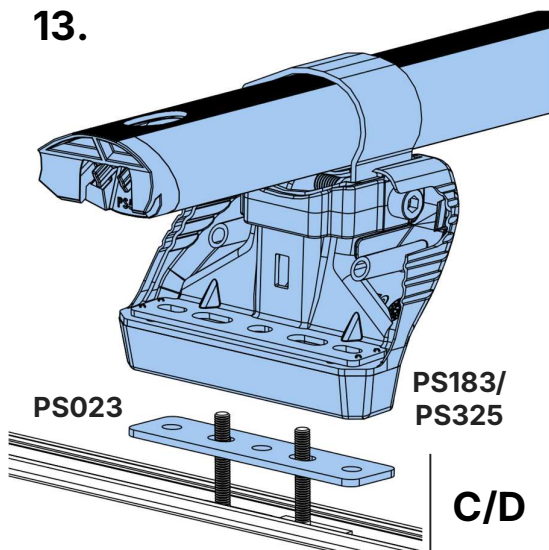
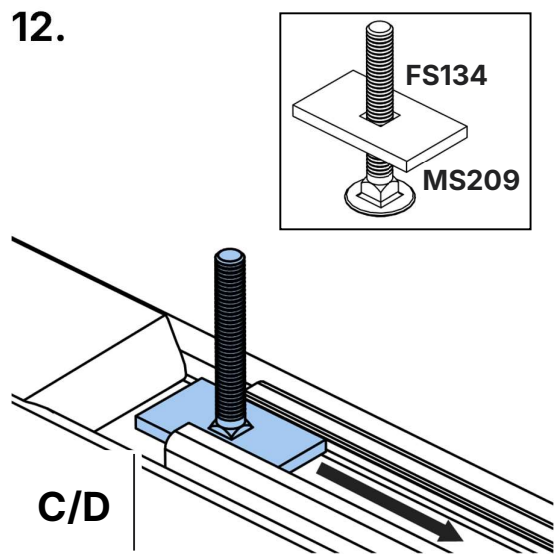
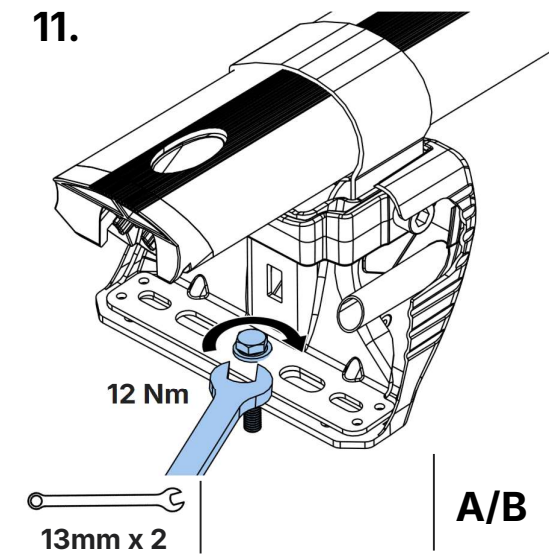
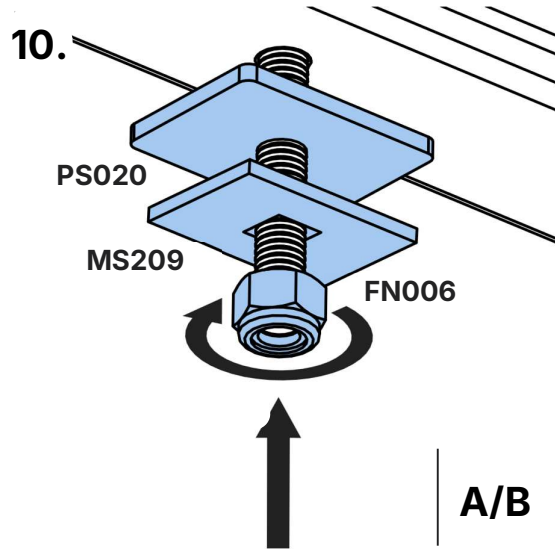
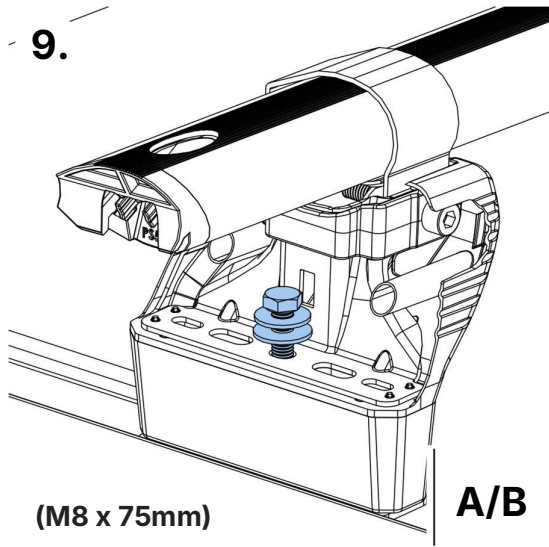

15.

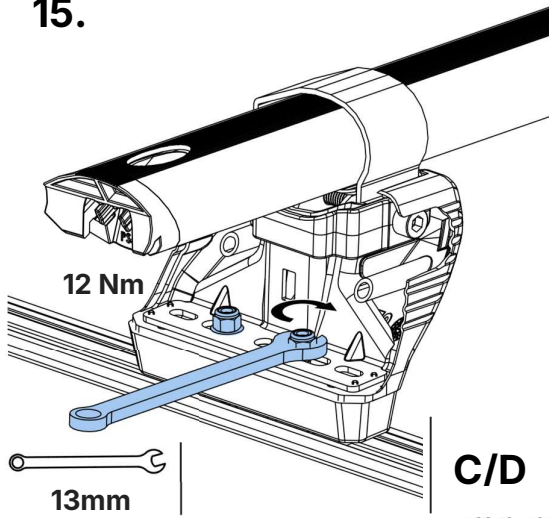

16.

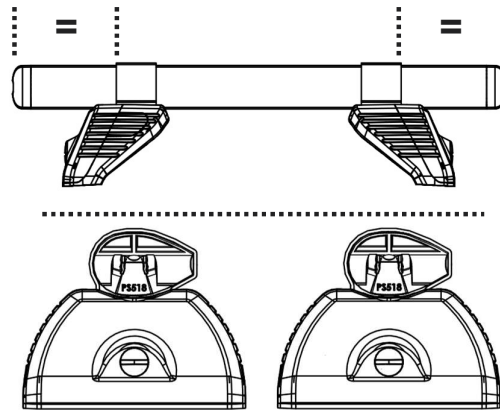

17.

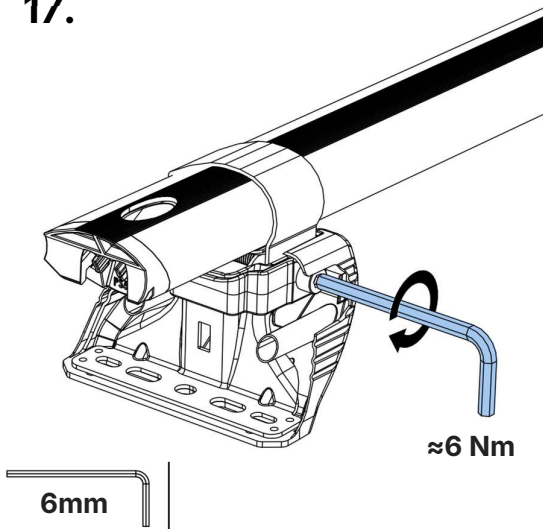

18.

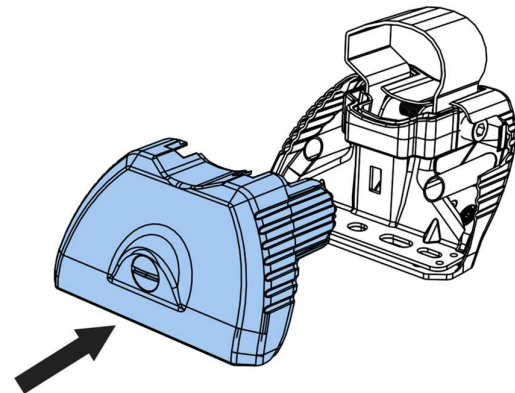

19.

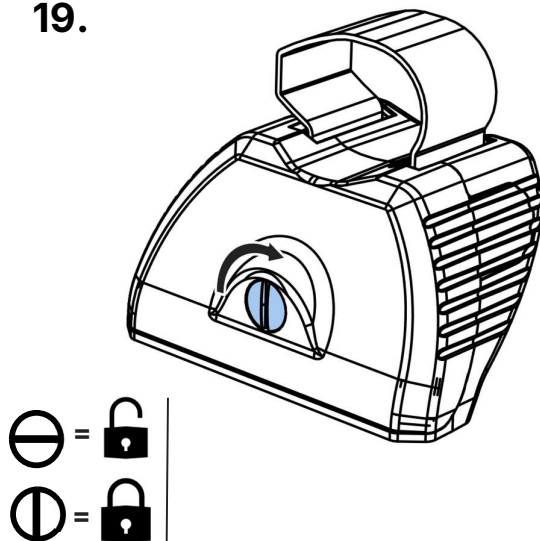

20.

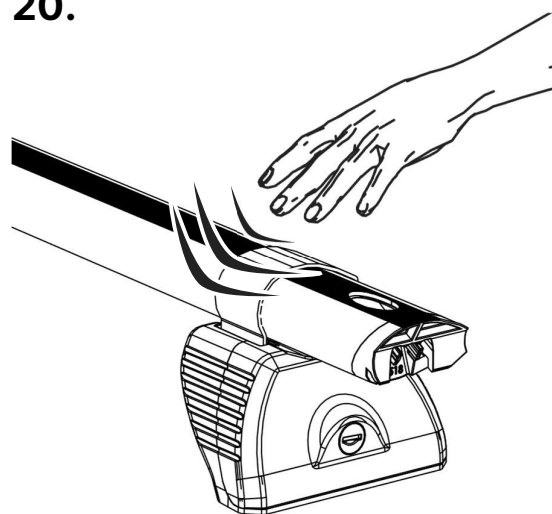

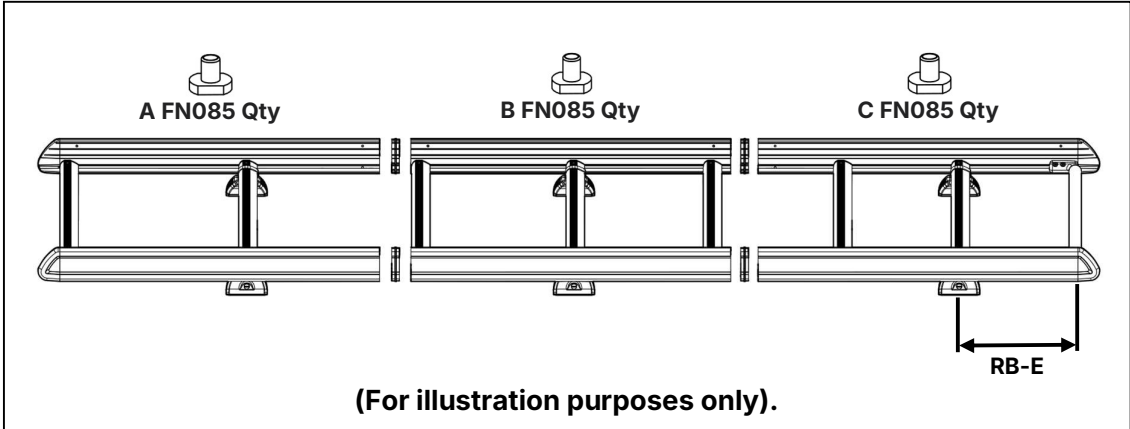

L667/LB667- TGE/Crafter 2017-, L4-H3 (Twin)

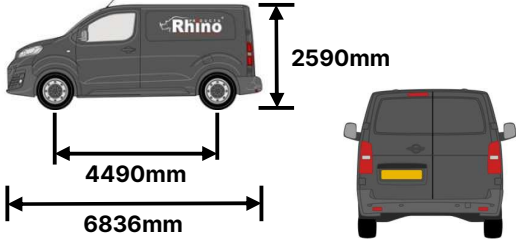
<p>Max Load = 150kg/330lbs</p>  <p>L667/LB667 = 42kg/93lbs</p>			
A FN085 Qty	B FN085 Qty	C FN085 Qty	Rear Bar – End (mm)
4	2	6	620

L670/LB670- TGE/Crafter 2017-, L5-H3 (Twin)

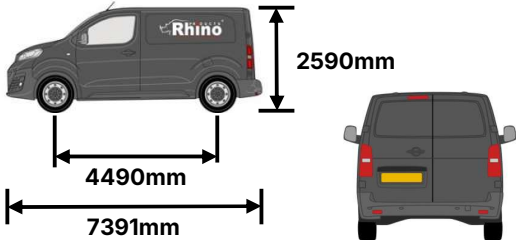
<p>Max Load = 150kg/330lbs</p>  <p>L670/LB670 = 45kg/99lbs</p>			
A FN085 Qty	B FN085 Qty	C FN085 Qty	Rear Bar – End (mm)
3	4	5	720

27.

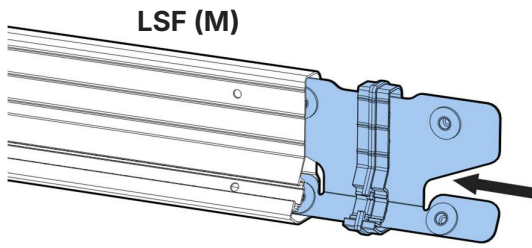

28.

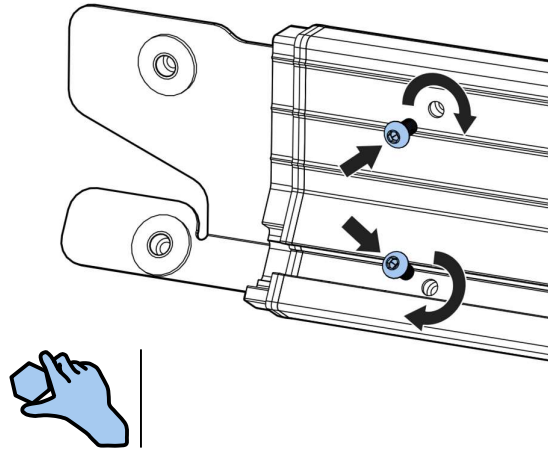

29.

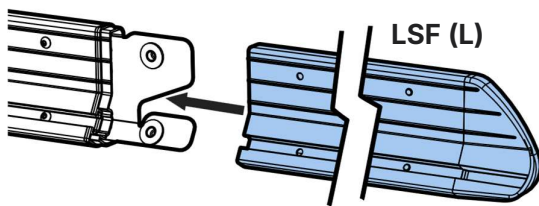

30.

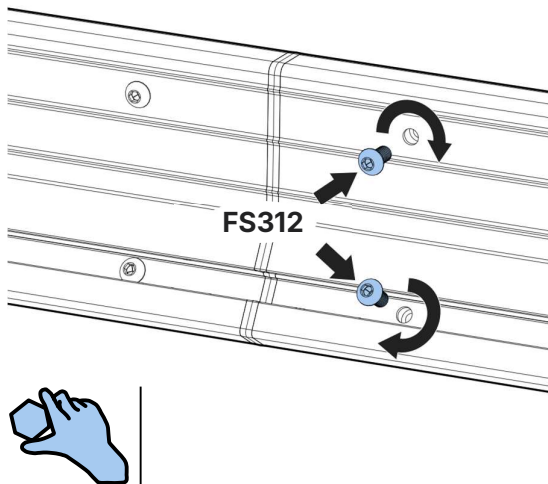

31.

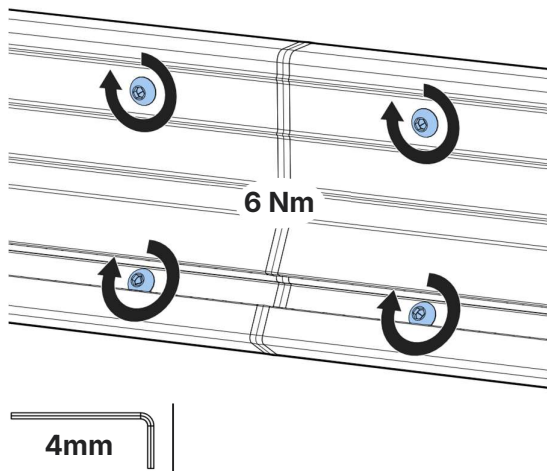

32.

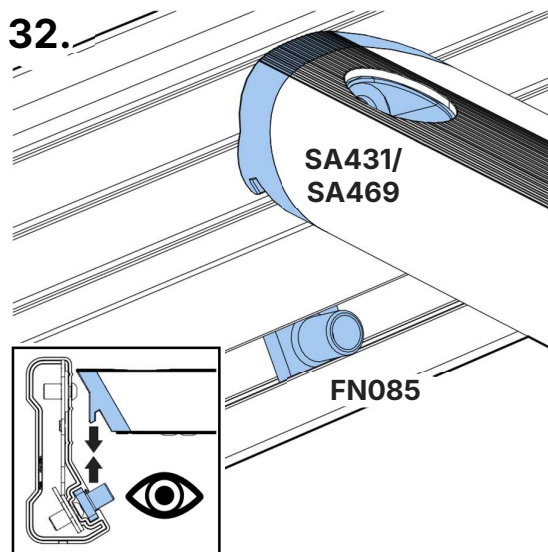

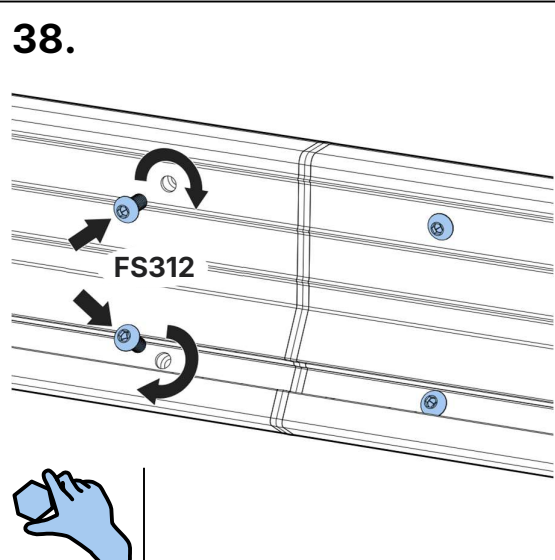
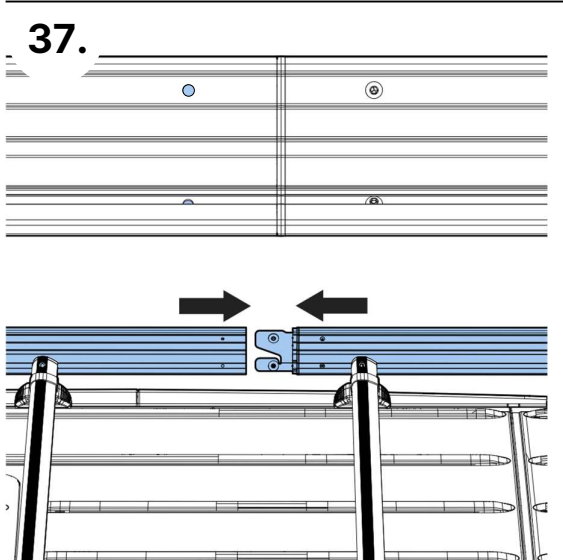
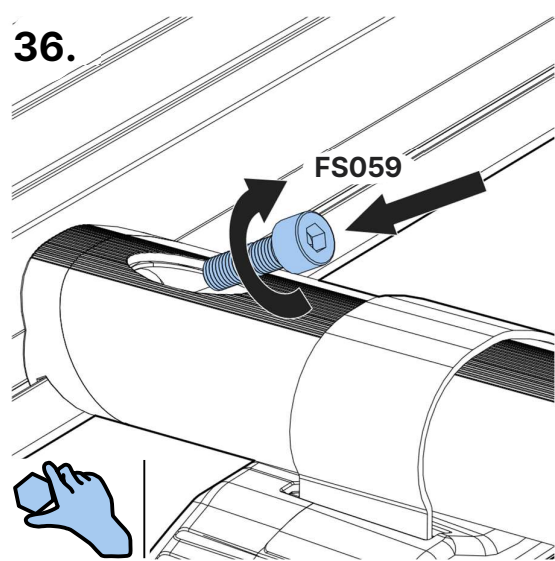
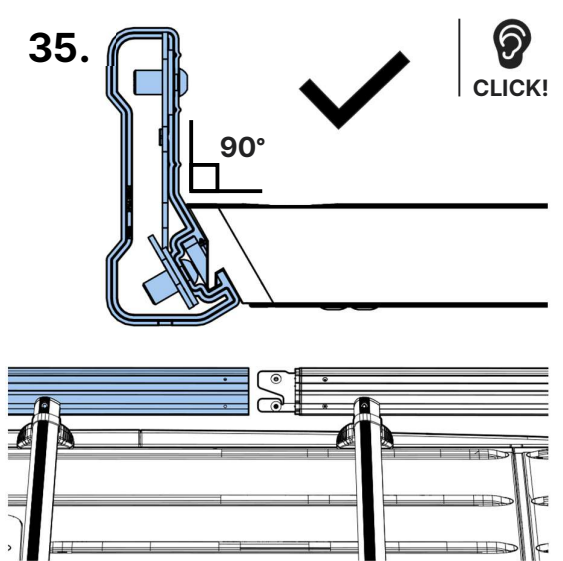
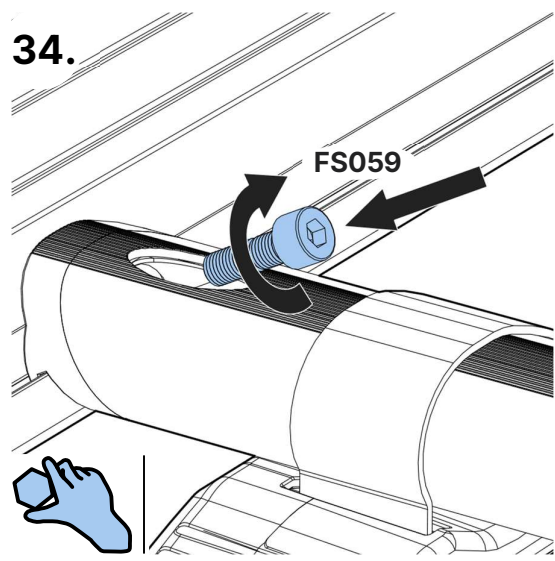
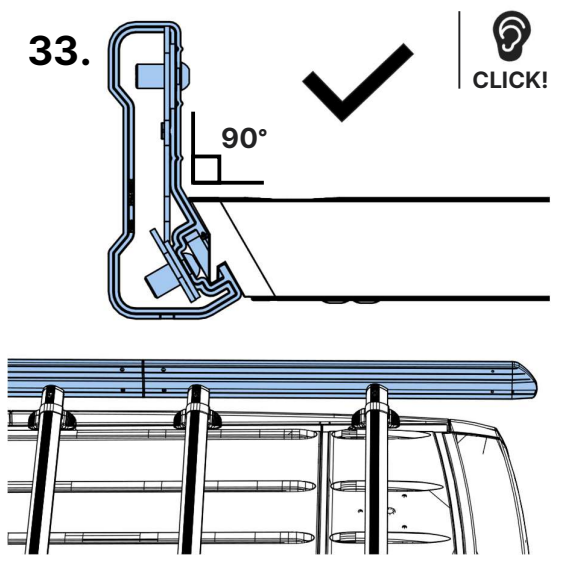

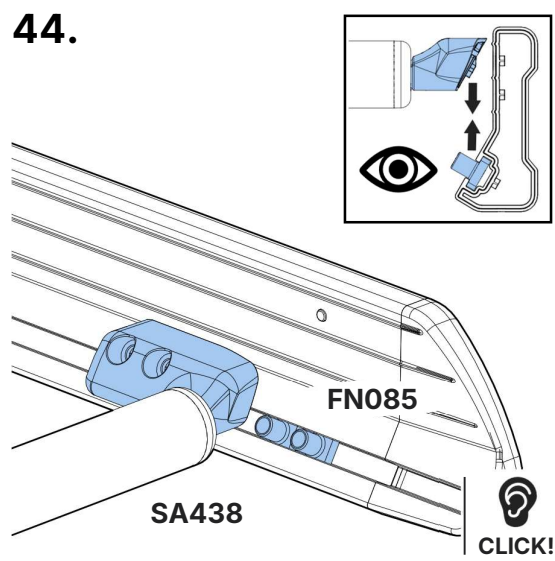
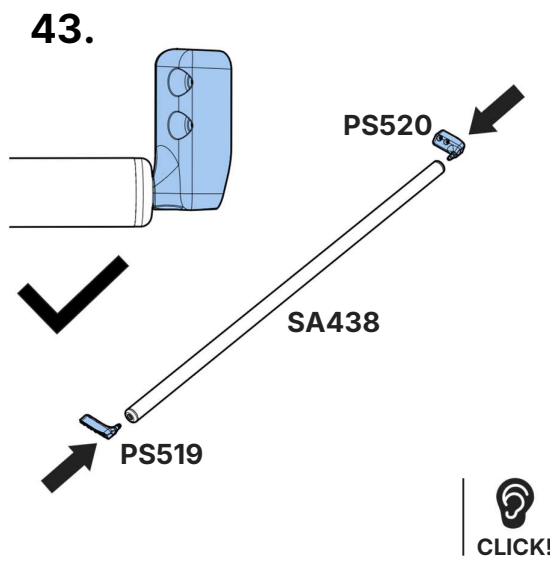
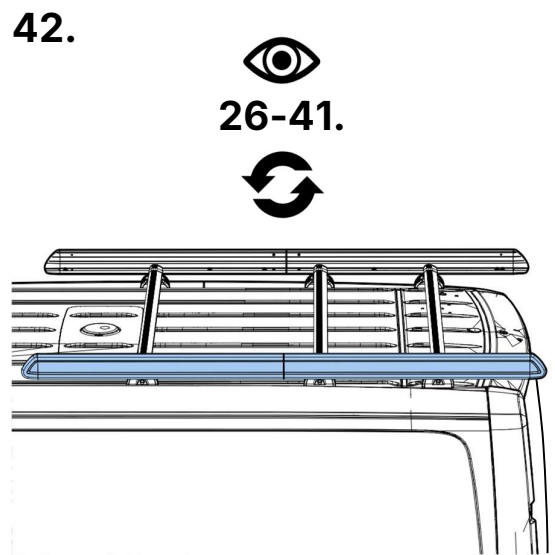
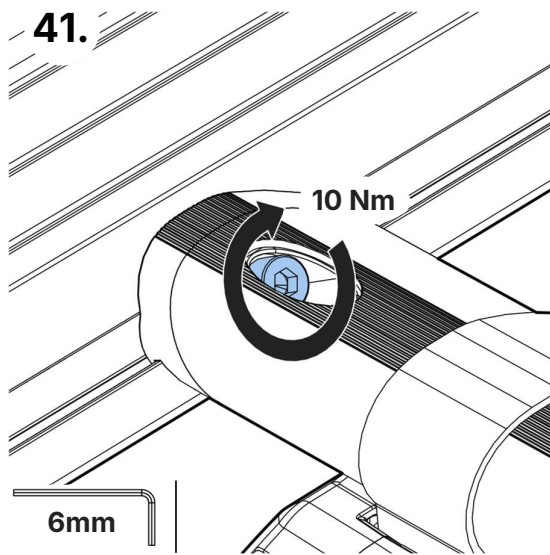
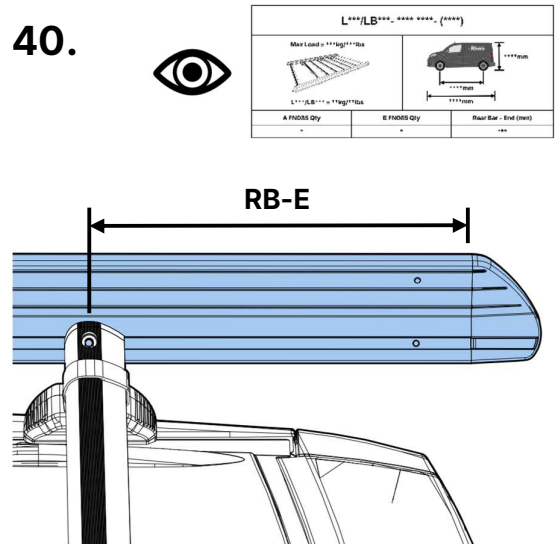
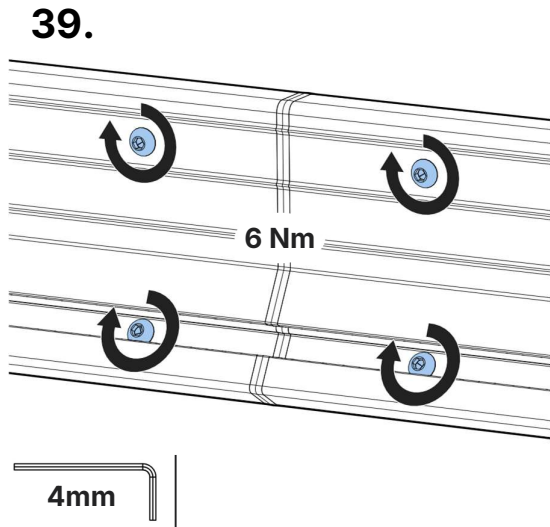

45.

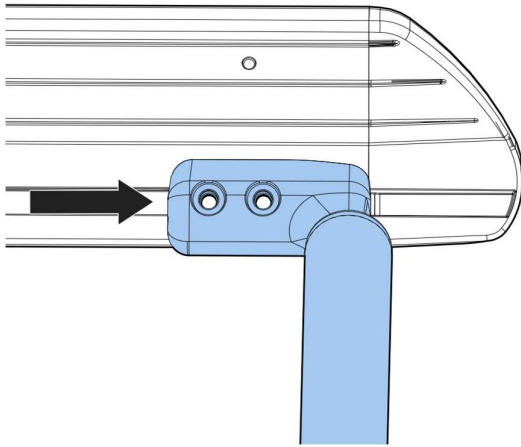

46.

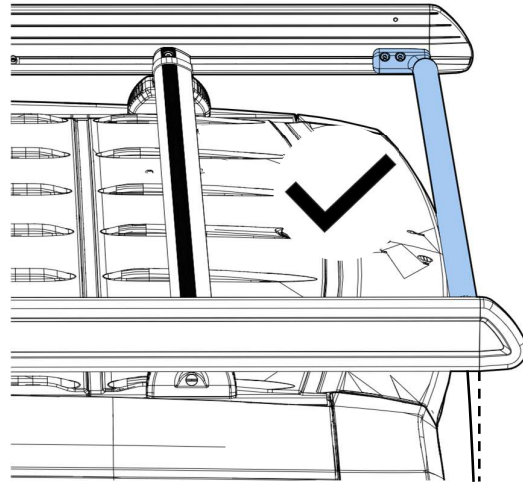

47.

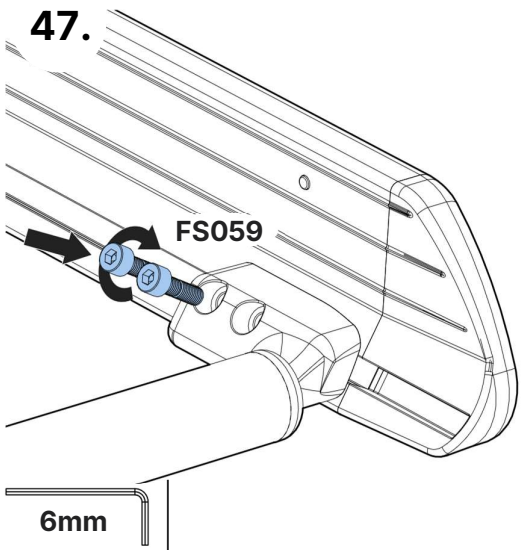

48.

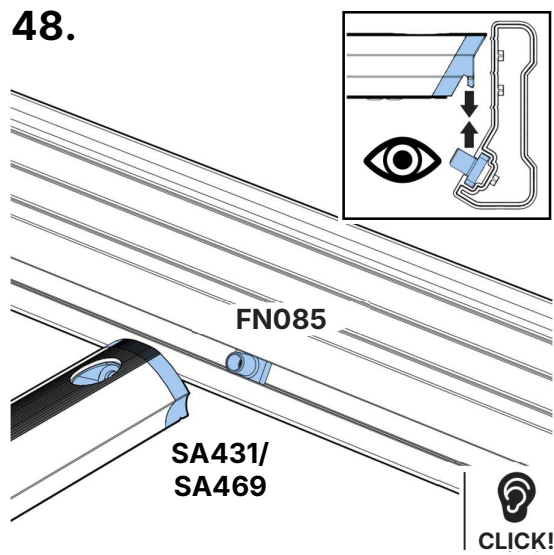

49.

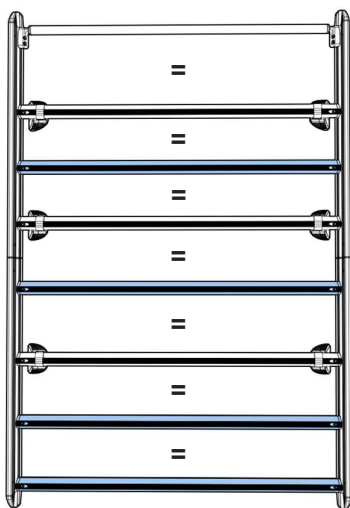

50.

